



Service Manual

FOR THE TURBOCHEF ENCORE™ AND ENCORE 2™ RAPID COOK OVENS



For further information, call
800.90TURBO
or
+1 214.379.6000

The information contained in this manual is important for the proper installation, use, maintenance, and repair of this oven. Follow these procedures and instructions to help ensure satisfactory baking results and years of trouble-free service.

Errors – descriptive, typographic, or pictorial – are subject to correction. Specifications are subject to change without notice.

Please carefully read this manual and retain it for future reference.

Table of Contents

Important Safety Instructions

General Safety Information	i
Reducing Fire Risk	i
Grounding Instructions	ii
Power Cord Replacement	ii
Precautions to be Observed Before and During Servicing to Avoid Possible Exposure to Excessive Microwave Energy	ii
RF Interference Considerations	ii

Specifications and Installation

Theory of Operation	1
Dimensions	1
Certifications	2
Oven Construction	2
Electrical Specifications	2
Installation	2
Unpacking Instructions	2
Installation Warnings - Read Before Lifting Oven	2
Installing the Oven	3
Installation Near Open Heat Source	3
Oven Restraint Kit	4
ChefComm Pro®	4
ChefComm Limited™	4
Oven Connect™	4
Voltage Selection	4
Ventilation	4

Oven Maintenance

Daily Maintenance	5
Quarterly Maintenance	7

Oven Controls and Cooking

Oven Controls	9
Cooking	10

Info Mode

Last Temperature Selected	13
Serial Number	13
Menu Version	13
Firmware Version	13
Cook Counters/Time Logs	13
Voltage - View Incoming	13
Fault Log	13
Service Numbers	13
Test Mode	13

Continued on next page...

Set Options	13
Cook More ON/OFF	13
Edit Mode ON/OFF	13
Load Menu ON/OFF	14
Network Setup	14
Auto Off ON/OFF	14
Auto On ON/OFF	14
Demo Mode ON/OFF	14
Light Ring ON/OFF	14
Set Date and Time	14
Load Menu from USB or Smart Card	15
Save Menu to USB or Smart Card	15
Sound Volume	15
Electrical Temperature	15
Reset the Oven	15
Firmware Update	16

Edit Mode

Set Temperature Edit	17
Baking Stone Use YES/NO	17
Bottom Temperature Offset	17
Select Groups and Items to Edit	17
Recipe Edit	18

Test Mode

Status Indicators	19
Magnetron Test	19
Blower Motor Test	19
Top Heater Test	20
Bottom Heater Test	20
Electrical Compartment (Ctl) Fan Test	20
Diagnostic Mode	20
Manufacturing Mode	20
Microwave Leakage Test	21
Burn in	21
Serial Number Edit	21
Self Test	21
Volt On	22
Erase/Default Oven Settings	22
Changing Temperature Measurement: F or C	22

Oven Systems

Impingement System	23
Blower Motor	23
Blower Motor Speed Controller (BMSC)	23
Heater - Top	23
Heater - Bottom	23
High Limit Thermostat	23
Jetplate - Bottom	23
RTD - Top and Bottom	23
Solid State Relay - K4/K5 Heaters	23
Troubleshooting	23

Oven Door	24
Removing/Reinstalling the Oven Door	24
Adjusting the Oven Door	24
Interlock Switches	25
Relay - K3 Monitor	25
Adjusting the Primary, Secondary, and Monitor Switches	25
Measuring RF Leakage for Microwave Safety	26
Troubleshooting	26
Microwave System	27
Capacitors	27
Testing a Capacitor	27
Filament Transformers	27
Wiring the Filament Transformers	27
High-Voltage Transformers	28
Wiring the High-Voltage Transformers	28
Testing a Filament or High-Voltage Transformer	28
High-Voltage Diodes	28
Testing a High-Voltage Diode	29
Magnetrons	29
Magnetron Cooling Fans	29
Magnetron Thermostats	30
Testing a Magnetron for an Open/Shorted Filament	30
Relay - K1 Filament	30
Relay - K2 Anode	30
Relay - K7 Encore: Magnetron Cooling Fans / Encore 2: All Cooling Fans	30
Waveguides	30
Troubleshooting	30
Control System	31
Control Board	31
Display	31
Ethernet Extension Cable	31
Keypad	31
LED Light Ring	31
Speaker	31
USB/Smart Card Reader	31
Troubleshooting	31
Power Components	32
Electrical Compartment Cooling Fan	32
Electrical Compartment Thermostat	32
Electrical Compartment Thermocouple	32
EMI Filter	32
Fuses	32
Power Supply	32
Relay - K6 Voltage	32
Relay - K7 Encore: Magnetron Cooling Fans / Encore 2: All Cooling Fans	32
Relay - K8 EC Cooling Fan	32
Voltage Sensor	32
Wire Harnesses	32
Troubleshooting	33

Continued on next page...

Filtering System	34
Catalytic Converter	34
Air Filter	34
Vent Catalyst	34
Troubleshooting	34

Troubleshooting

Overview of Troubleshooting	35
Fault Code Descriptions	35
F1 Blower Running Status Bad	37
F2 Cook Temperature Low	38
F3 Magnetron Current Low	39
F4 Door Monitor Defective	40
F5 Magnetron Over Temperature	40
F6 Electrical Compartment Temperature High	41
F7 RTD Open	41
F8 Heat Low	42
F9 Cook Cavity Temperature High	42
No Keypad Input	43
“Cook Door Open” Message when Door is Closed	43
No Display (Screen is Blank)	44
Food Not Cooking Properly	45
Troubleshooting: “Failed 240,” “No Card,” or “Write Fail” Message when Loading or Saving a Menu	46
Steam Present During or After Cooking	46

Encore Oven Schematic and Wire Harnesses

Relay Schematic	47
Oven Schematic	48
Wire Harness: HV Microwave Circuit 1	50
Wire Harness: HV Microwave Circuit 2	50
Wire Harness: Low Voltage	52
Wire Harness: Heater	52
Wire Harness: Cooling Fans	54
Wire Harness: Main Line Voltage	56-59

Encore 2 Oven Schematic and Wire Harnesses

Relay Schematic	61
Oven Schematic	62
Wire Harness: Heater	64
Wire Harness: HV Microwave Circuit 1	66
Wire Harness: HV Microwave Circuit 2	66
Wire Harness: Low Voltage	66
Wire Harness: Main Line Voltage	68-71
Wire Harness: Cooling Fans	72

Encore Appendix - Replacing Oven Components

Replacing Oven Components	A-1
Oven Exterior	A-2
Impingement System	A-4
Microwave System	A-6
Oven Door and Related Parts	A-8
Control System	A-10
Power Components	A-12 – A-15

Encore 2 Appendix - Replacing Oven Components

Replacing Oven Components	A-17
Oven Exterior	A-18
Impingement System	A-20
Microwave System	A-22
Oven Door and Related Parts	A-24
Control System	A-26
Power Components	A-28 – A-31

IMPORTANT SAFETY INSTRUCTIONS

- ⚠ WARNING:** When operating this oven, strictly adhere to the following safety precautions to reduce the risk of burns, electric shock, fire, injury, damage to oven or property near oven, or possible exposure to excessive microwave energy.

GENERAL SAFETY INFORMATION

- ✓ Read all instructions before using this appliance.
- ✓ Read and follow the specific “Precautions to be Observed to Avoid Possible Exposure to Excessive Microwave Energy” found on page ii.
- ✓ This appliance must be grounded. Connect only to a properly grounded outlet. See “Grounding Instructions” on page ii.
- ✓ Install or locate this appliance only in accordance with the provided installation instructions.
- ✓ This appliance should be serviced by qualified service personnel only. Contact the nearest authorized service facility for examination, repair, or adjustment.
- ✓ Keep the cord away from heated surfaces.
- ✓ Liquids, such as water, coffee, or tea are able to be overheated beyond the boiling point without appearing to be boiling. Visible bubbling or boiling when the container is removed from the microwave oven is not always present. **THIS COULD RESULT IN VERY HOT LIQUID SUDDENLY BOILING OVER WHEN THE CONTAINER IS DISTURBED OR A UTENSIL IS INSERTED INTO THE LIQUID.**
- ✓ **WARNING:** The contents of feeding bottles and baby food jars must be stirred or shaken and the temperature checked before consumption, in order to avoid burns (IEC 60335-2-90).
- ✓ Use this appliance only for its intended uses as described in this manual.
- ✓ Only use utensils that are suitable for use in microwave ovens (IEC 60335-2-90).
- x **DO NOT** use corrosive chemicals or vapors in this appliance; it is not designed for industrial/laboratory use.
- x **WARNING: DO NOT** heat liquids or other foods in sealed containers (e.g., jars, whole eggs, etc.) since they are liable to explode.
- x **DO NOT** allow children to use this appliance.
- x **DO NOT** operate this appliance if it has a damaged cord or plug, is not working properly, or has been damaged or dropped. See “Power Cord Replacement” found on page ii.
- x **DO NOT** cover or block any openings on this appliance.
- x **DO NOT** store this appliance outdoors.
- x **DO NOT** use this product near water (e.g., near a kitchen sink, in a wet basement, near a swimming pool).
- x **DO NOT** immerse the cord or plug in water.
- x **DO NOT** let the cord hang over the edge of a table or counter.
- x **DO NOT** use a water jet for cleaning. See pages 5-7 in this manual for proper cleaning procedures.
- x **DO NOT** use this product without the bottom jetplate installed. The oven will not cook properly and damage to the oven may occur.
- x This appliance is not to be used by children or persons with reduced physical, sensory or mental capabilities, or lack of experience and knowledge, unless they have been given supervision or instruction.

REDUCING FIRE RISK

- ✓ Remove wire twist-ties from paper or plastic bags used to facilitate cooking in the oven.
- ✓ If materials inside the oven ignite, keep the oven door closed, turn the oven off, and disconnect the power cord or shut off power at the fuse or circuit breaker panel.
- ✓ If smoke is observed, switch off or unplug the oven. Keep the door closed to stifle any flames.
- x **DO NOT** use the cook cavity for storage purposes.
- x **DO NOT** overcook food. Carefully attend to the oven if paper, plastic, or other combustible materials are placed inside the oven to facilitate cooking.
- x **DO NOT** leave paper products, cooking utensils, or food in the cavity when the oven is not in use.

SAVE THESE INSTRUCTIONS

GROUNDING INSTRUCTIONS

This appliance must be grounded. In the event of an electrical short circuit, grounding reduces the risk of electric shock by providing an escape wire for the electric current. This oven is equipped with a cord that has a grounding wire with a grounding plug, which must be plugged into an outlet that is properly installed and grounded. Consult a qualified electrician or serviceman if uncertain about the ability to follow grounding instructions or if in doubt as to whether the appliance is properly grounded.

- x DO NOT use an extension cord. If the power cord is too short, have a qualified electrician or serviceman install an outlet near the appliance.

 **WARNING:** Improper grounding can result in risk of electric shock.

POWER CORD REPLACEMENT

If the power cord is damaged, it must be replaced by the manufacturer, its service agent, or a similarly qualified person.

PRECAUTIONS TO BE OBSERVED BEFORE AND DURING SERVICING TO AVOID POSSIBLE EXPOSURE TO EXCESSIVE MICROWAVE ENERGY

- (a) Do not operate or allow the oven to be operated with the door open.
- (b) Make the following safety checks on all ovens to be serviced before activating the magnetron or other microwave source, and make repairs as necessary: (1) interlock operation, (2) proper door closing, (3) seal and sealing surfaces (arcing, wear, and other damage), (4) damage to or loosening of hinges and latches, (5) evidence of dropping or abuse.
- (c) Before turning on microwave power for any service test or inspection within the microwave generating compartments, check the magnetron, wave guide or transmission line, and cavity for proper alignment, integrity, and connections.
- (d) Any defective or misadjusted components in the interlock, monitor, door seal, and microwave generation and transmission systems shall be repaired, replaced, or adjusted by procedures described in this manual before the oven is released to the owner.
- (e) A microwave leakage check to verify compliance with the Federal Performance Standard should be performed on each oven prior to release to the owner. Refer to page 26 for leakage test procedures.

RF INTERFERENCE CONSIDERATIONS

The oven generates radio frequency signals. This device has been tested and was determined to be in compliance with applicable portions of FCC part 18 requirements and to the protection requirements of Council Directive 89/336/EEC on the approximation of the laws of the Member States relating to electromagnetic compatibility at the time of manufacture. However, some equipment with sensitivity to signals below these limits may experience interference.

If your equipment experiences interference:

- ✓ Increase the physical separation between this oven and the sensitive equipment.
- ✓ If the sensitive device can be grounded, do so following accepted grounding practices.
- ✓ If battery-powered microphones are being affected, ensure that the batteries are fully charged.
- ✓ Keep sensitive equipment on separate electrical circuits if possible.
- ✓ Route intercom wires, microphone wires, speaker cables, etc. away from the oven.

SAVE THESE INSTRUCTIONS

Specifications and Installation

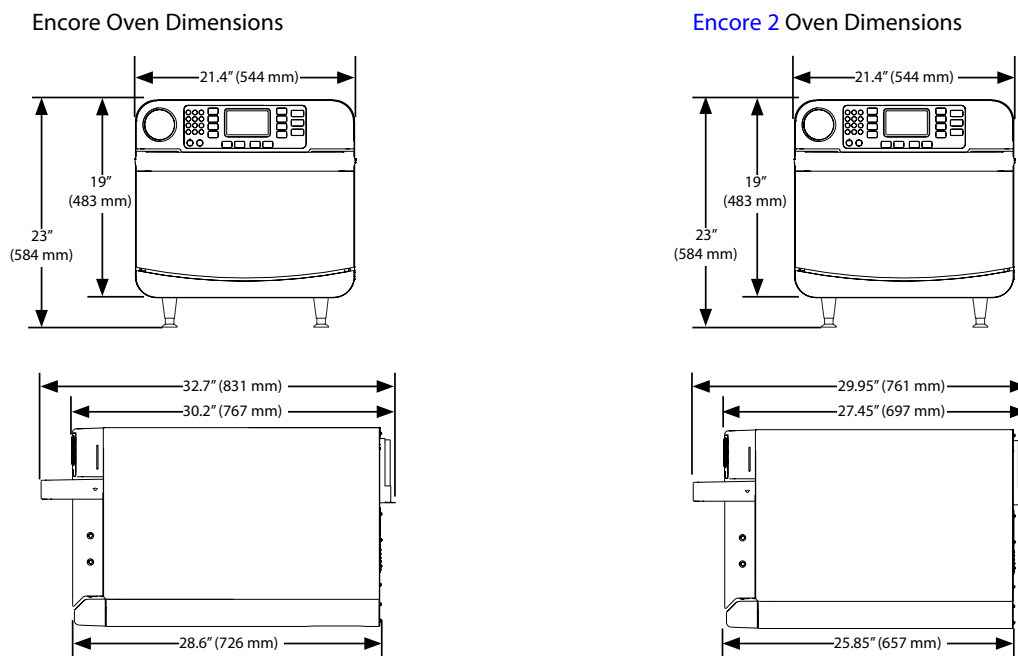

Figure 1: Encore and **Encore 2** Oven Dimensions

Theory of Operation

The TurboChef Encore/**Encore 2** oven uses radiant heat in combination with high-speed air impingement and side-launched microwave to cook food rapidly without compromising quality. Performance and menu versatility are maximized due to flexible top and bottom temperature settings and the ability to set the amount of microwave and air in different phases of each recipe.

This manual includes instructions for installing, cleaning, and operating the oven. If you have questions that are not addressed in this manual, contact Customer Support at 800.90TURBO (USA) or +1 214.379.6000 (International), or your Authorized Distributor.

Dimensions

Oven Dimensions

- Height - Single Oven
 - with legs: 23" (584 mm)
 - without legs: 19" (483 mm)
- Height - Stacked Ovens
 - lower oven with legs: 42" (1,067 mm)
 - lower oven without legs: 38" (965 mm)
- Width: 21.4" (544 mm)
- Depth (Encore)
 - footprint: 28.6" (726 mm)
 - door closed: 32.7" (831 mm)
 - door open: 39.4" (1,000 mm)
- Depth (**Encore 2**)
 - footprint: 25.85" (657 mm)
 - door closed: 29.95" (761 mm)
 - door open: 36.31" (922 mm)
- Weight: 185 lb. (84 kg)

Cook Cavity Dimensions

- Height: 6.0" (152 mm)
- Width: 15.5" (394 mm)
- Depth: 14.5" (368 mm)
- Volume: 0.78 ft³ (22.1 liters)

Clearances

- Top: 5" (127 mm)
- Sides: 2" (51 mm)

Certifications

cULus, UL EPH, TÜV, CE, FDA



Oven Construction

Exterior

- Powder coated, corrosion-resistant steel outer wrap
- Powder-coated aluminum steel front panels and door
- Cool-to-touch exterior; all surfaces below 122°F (50°C)
- Ergonomic door handle

Interior

- 201 stainless steel
- Fully welded and insulated cook chamber
- Removable rack and lower jetplate for cleaning

Electrical Specifications

TurboChef recommends a Type D circuit breaker for all installations outside the United States.

Single Phase (6200 watts)

US/Canada: 208/240 VAC*, 60 Hz, 30 A
 Europe/Asia (UK): 230 VAC, 50 Hz, 30 A
 Brazil (BK): 220 VAC, 60 Hz, 30 A
 Latin America (LA): 220 VAC, 60 Hz, 30 A
 Japan (JK): 200 VAC, 50 or 60 Hz, 30 A

Multiphase (6200 watts)

Europe/Asia Wye (EW): 400 VAC, 50 Hz, 16 A
 Europe/Asia Delta (ED): 230 VAC, 50 Hz, 30 A
 Japan Delta (JD): 200 VAC, 50 or 60 Hz, 30 A
 Korea/Middle East Wye (KW): 400 VAC, 60 Hz, 16 A
 Korea/Middle East Delta (SD): 230 VAC, 60 Hz, 30 A

* US/Canada models include a voltage sensor that detects 208 or 240 VAC, but does not compensate for lack-of or over-voltage installations.

Installation

Install or locate this appliance only in accordance with the instructions below.

Unpacking Instructions

1. Remove the oven from its packaging.
2. Before throwing the packaging away, check it thoroughly for accessories and literature.

NOTE: Keeping the packaging is recommended in case the oven may be shipped to another location.

3. Check the cook cavity thoroughly for packaging, accessories, and literature.
4. Discard any packaging in the cook cavity.

Installation Warnings - Read Before Lifting Oven

 **WARNING:** The oven weighs approximately 185 lb. (84 kg). Never lift with fewer than two people.

 **WARNING:** Never lift the oven by the door handle. Doing so will cause the door to misalign, resulting in a non-warranty service call.

 **WARNING:** The oven must be properly placed on a food station at all times. TurboChef will not recognize a fallen oven as a warrantable claim and is not liable for any injuries that may result.

 **WARNING:** This oven is not intended for built-in installation (i.e., installing the oven in any structure that surrounds the oven by five or more sides). Be sure to provide a minimum of 2" (51 mm) clearance for all sides and 5" (127 mm) clearance for the top.

 **WARNING:** This oven is not intended to be stacked without appropriate hardware. Contact TurboChef for details.

 **WARNING:** Never stack ovens more than two high.

Installing the Oven

1. Prepare a surface capable of supporting 190 lb. (86 kg) or 380 lb. (172 kg) if stacking. The surface must be this deep:
 - Encore: 30.2" (767 mm)
 - **Encore 2**: 27.45" (697 mm)
2. If installing onto an oven cart:
 - a. Ensure the oven cart casters are locked.
 - b. Ensure the oven legs are removed.
 - c. Drilling additional holes in the counter surface/cart for stability is required if the existing holes in the cart/surface do not align with the leg holes of the oven. For details, contact customer support at 800.90TURBO or +1 214.379.6000.
3. Position one or more persons at the front and back of the oven.
4. Place hands under the oven and lift.
5. Place the oven on the prepared surface, ensuring no edges are hanging off the sides.
6. If stacking two ovens:
 - a. See page 1 for dimensions.
 - b. Install the stacking bracket (part number ENC-3001) to the lower oven.

NOTE: If stacking an Encore and **Encore 2**, the Encore oven must be placed on the bottom.

- c. Place the upper oven on top of the lower oven.
- d. Secure the bracket to the top oven.

7. Ensure the oven rack is properly installed (attached to the bottom jetplate).
8. Plug in the oven.

NOTE: The oven is primarily serviced through its sides and top. Shelving installed directly over the unit may delay servicing. The owner will be responsible for paying service costs for added time spent clearing access to the oven.

Installation Near Open Heat Source

When placing a TurboChef oven near an open heat source (Figure 2 below), strictly adhere to the following:

- If the oven is being placed near a grill or stove, a divider must exist between the oven and the open heat source, with a minimum of 6" (152 mm) between the oven and the divider.
- If the oven is being placed near a fryer, a divider must exist between the oven and fryer, with a minimum of 12" (305 mm) between the oven and the divider.
- The height of the divider must be greater than or equal to the height of the oven (see page 1).
- Verify the oven location has a minimum 5" (127 mm) clearance on top and a minimum 2" (51 mm) clearance on each side.

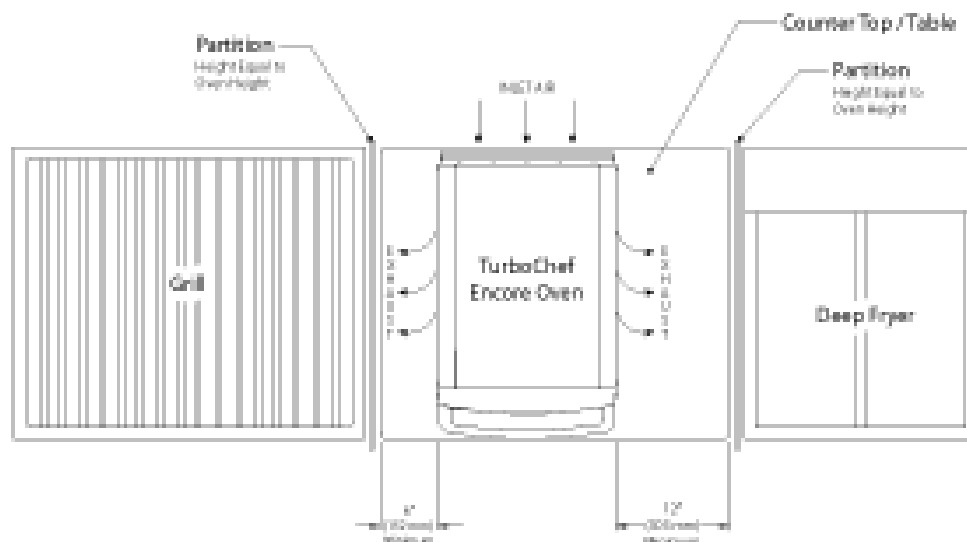

Figure 2: Installation Near Open Heat Source

Oven Restraint Kit

Part Number: [TC3-0242](#)



WARNING: The Oven Restraint Kit will not prevent the oven from falling off a countertop if the oven is pulled off or allowed to slide off the edge. Installation instructions are included with the kit.

ChefComm Pro®

Part Number: [CON-7006](#)

ChefComm Pro® lets you easily create menu settings on a computer and upload them to an oven via smart card or USB. For more information, call TurboChef Customer Support at 800.90TURBO or +1 214.379.6000.

ChefComm Limited™

Part Number: [CON-7016](#)

ChefComm Limited™ is a “read-and-upload only” version of ChefComm Pro® that helps ensure menu settings are easy to distribute, while preventing them from being changed at the store level.

Oven Connect™

Oven Connect™ allows you to update menu settings for multiple ovens at once, from one central location via LAN. Oven Connect™ can also download oven diagnostics and counters from the oven to your computer. For more information on how to network ovens, see page 14. For information on Oven Connect, contact TurboChef Customer Support at 800.90TURBO or +1 214.379.6000.

Voltage Selection

For North America oven models, the oven will detect 208 or 240 incoming voltage.

If incoming voltage for the store is different than the factory-preset voltage, the operator will be required to select either 208 or 240 after pressing the On/Off key to turn on the oven. The correct voltage will be enlarged on the screen, identifying which option to select (see below).



Figure 3: Select Voltage

Ventilation

The TurboChef Encore/[Encore 2](#) oven has been approved by Underwriter’s Laboratory® for ventless operation (UL 710B, KNLZ listing) for all food items except for foods classified as “fatty raw proteins.” Such foods include bone-in, skin-on chicken, raw hamburger meat, raw bacon, raw sausage, steaks, etc. If cooking these types of foods, consult local HVAC codes and authorities to ensure compliance with ventilation requirements.

NOTE: In no event shall the manufacturer assume any liability for damages or injuries resulting from installations which are not in compliance with the instructions and codes previously listed.

Daily and Quarterly Maintenance

Daily Maintenance

Follow the steps below when cleaning your oven. Use only TurboChef® -approved cleaning chemicals. Failure to adhere to these procedures or the use of any other cleaning products may damage critical oven components, resulting in a non-warranty service call.



Step 1



Step 2



Step 3



Step 4

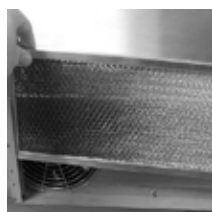

Step 5

Supplies and Equipment

TurboChef® Oven Cleaner (Product Number: 103180), TurboChef® Oven Guard (Product Number: 103181), Kay ClickSan® sanitizer, nylon scrub pad, clean damp and dry towels, disposable gloves, protective eyewear, dust mask (optional)

Step 1: Cool the Oven

⚠ WARNING: The oven operates at approximately 500°F (260°C) and may cause injury if not allowed to cool properly.

- Turn off the oven by pressing the On/Off key.
- Slightly open the oven door.
- Cooling takes approximately 30 minutes.

⊘ DO NOT proceed to Step 2 until the oven displays “ready to clean.”

Step 2: Clean the Wire Rack

- The wire rack is held in place by tabs that are positioned underneath either side of the jetplate.
- Lift the rear of the wire rack.
- Pull the wire rack forward until the tabs are free.
- Wash, rinse, sanitize, and dry the wire rack.

Step 3: Clean the Jetplate

- Lift the front of the jetplate.
- Pull the jetplate forward and remove it from the oven.

⚠ CAUTION: Handle the jetplate with care to avoid chipping the porcelain coating.

- Wash, rinse, sanitize, and dry the jetplate.

⊘ DO NOT clean the jetplate with a wire brush.

Step 4: Clean the Cavity Filter (if present)

The filter must remain in place during oven operation, and it must be cleaned regularly or replaced if damaged.

- Remove the cavity filter from the back cavity wall by lifting the tab and pulling the filter towards you.
- Rinse the filter with hot water.
- Allow the filter to dry completely.

⊘ DO NOT scrub or pull apart the mesh in the filter frame.

Step 5: Clean the Air Filter

The filter must remain in place during oven operation, and it must be cleaned regularly or replaced if damaged.

- Remove the air filter from the back of the oven.
- Rinse the air filter with hot water.
- Allow the air filter to dry completely.



Step 6

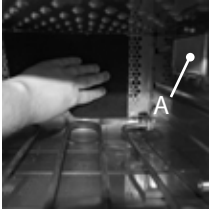

Step 7

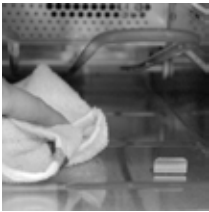

Step 8



Step 9



Step 10



Step 11



Step 12

Step 6: Remove Large Food Particles

- The heating element can be lifted for cleaning underneath.
- ⊘ DO NOT attempt to clean the heating element.
- Use a food vacuum or damp towel to remove large particles from the oven cavity.

Step 7: Clean the Oven Cavity

- ⊘ DO NOT spray TurboChef® Oven Cleaner into the holes in the oven cavity.
- Apply Oven Cleaner to a towel or nylon scrub pad and clean the top, sides, and bottom of the cavity.
- ⊘ DO NOT apply excessive pressure to the waveguide covers (A), located on each side of the cavity.
- For stubborn stains, sparingly spray Oven Cleaner on the stain.
- Allow the Oven Cleaner to penetrate the stain for five minutes, then wipe clean.
- ⊘ DO NOT use a hose or water jet for cleaning.

Step 8: Wipe Down the Oven Cavity

- Wipe down the oven cavity with a damp towel.
- Dry the oven cavity with a dry towel.

Step 9: Clean and Dry the Oven Door

- Clean the oven door with Oven Cleaner and a nylon scrub pad.
- Wipe the oven door with a damp towel.
- Dry the oven door with a dry towel.

Step 10: Apply TurboChef® Oven Guard

- Spray TurboChef® Oven Guard onto a dry towel.
- Wipe the cavity walls and the inside of the oven door.
- ⊘ DO NOT spray Oven Guard into the oven or apply to the heating element.

Step 11: Reinstall Components

- Reinstall the cavity filter (if present). Be sure to align the top-left post on the back of the filter with the top-left hole on the back cavity wall. This will ensure the other posts on the back of the filter fit into the wall.
- Reinstall the jetplate and the wire rack.
- ⊘ DO NOT operate the oven without the bottom jetplate installed. Doing so may damage the oven.
- Close the oven door.
- Reinstall the filter, or replace it with a new one if the mesh is deteriorated, has large openings, or has started to dislodge from the frame.

Step 12: Clean the Oven Exterior

- Wipe the oven exterior with a damp towel.
- Remove the panel beneath the door, remove any large food particles from the panel, and wipe it with a damp towel.
- Reinstall the panel beneath the door.
- ⊘ DO NOT spray chemicals into any openings, such as the louvers on the side panels or the rear vent catalyst housing.
- The oven is ready to turn on.

Quarterly Maintenance

To ensure optimal oven performance, complete the following cleaning steps once per quarter or more frequently as required.



1. Complete the daily cleaning instructions (pages 5-6).



CAUTION: Make sure the oven is off before proceeding.

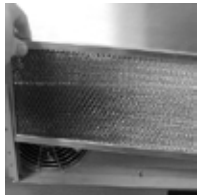

2. Remove the air filter.



3. Clean the cooling fans and finger guards.

NOTE: A bristle or paint brush and vacuum are recommended for collecting the debris.



4. Clean the louvers on both side panels.

NOTE: A bristle or paint brush and vacuum are recommended for collecting the debris.



5. Using a Phillips screwdriver, remove the screws from the rear vent catalyst housing. Support the cover with your hand.

Supplies and Equipment

Required: Phillips screwdriver, clean towels, rubber gloves for handling catalytic converter

Recommended: dust mask, vacuum, bristle or paint brush



6. The catalytic converter is accordion style and will pop out when the cover is removed. Remove the cover slowly to keep the catalytic converter in place.



CAUTION: DO NOT attempt to clean the catalytic converter or spray chemicals in this area.

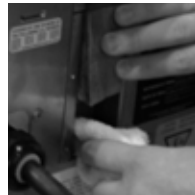

7. Clean the housing:
 - Hold the catalytic converter in place with one hand.
 - Using a clean towel, wipe out any debris that has accumulated beneath the catalytic converter.
 - Clean the outer cover and make sure the vent holes are not blocked.



8. Reattach the outer cover, making sure the vent holes are at the bottom.



CAUTION: Installing the outer cover upside down could result in excessive grease buildup and/or hot steam present when the oven door is opened.

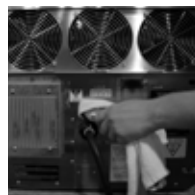

9. Wipe down the back panel with a clean, damp towel.

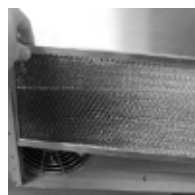

10. Reinstall the air filter. The oven is ready to turn on.

*This page intentionally
left blank.*

Oven Controls and Cooking

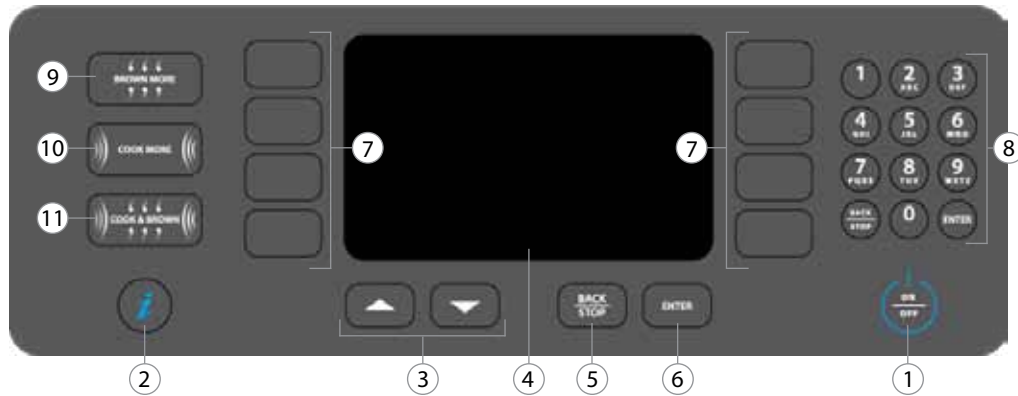

Figure 4: Oven Controls

Oven Controls

1. On/Off Key

Press to turn the oven on (begin warmup) or off (cool down), or to exit Info Mode (page 13).

2. "i" Key

When the oven is off or cooling down, press to access the Info Mode (page 13).

3. Up and Down Keys

When the oven is ready to cook (i.e., warmed up and waiting for a cook command), press the Up or Down key to view additional food groups or items.

When the oven is in the Info Mode (page 13), press to switch between screens 1 and 2.

When editing a food item, press to move the cursor between editable fields (page 18).

4. Display

The display shows information relevant to the current oven operation and/or user options.

5. Back/Stop Key

When the oven is cooking, press the Back/Stop key to immediately terminate a cook cycle.

When the oven is ready to cook (i.e., warmed up and waiting for a cook command), or in the Info Mode (page 13), press the Back/Stop key to return to the previous screen.

6. Enter Key

Press the Enter key when saving changes to food item settings (page 18), or whenever instructed by the oven screen.

7. Soft Keys

There are eight soft keys - four to the left and right of the display. Press a soft key to select an option adjacent to that key on the display.

8. Numeric Keypad

Use the numeric keypad to enter passwords or modify cook settings (page 18). The numeric keypad also contains a Back/Stop key and an Enter key, which are functionally identical to Items 5 and 6.

9. Brown More Key

Press "Brown More" if the outside of the food item requires browning or crisping. See page 11, step 8 for details.

10. Cook More Key

Press "Cook More" if the inside of the food item requires cooking. See page 11, step 8 for details.

11. Cook & Brown Key

Press "Cook & Brown" if both the inside and outside of the food item require cooking. See page 11, step 8 for details.

Cooking

The oven is preprogrammed with recipe settings at the time of manufacture and is ready to operate out of the box. New menu settings can be loaded via USB or smart card (page 15) or programmed manually (page 17). **The oven will not cook unless settings are present.**

This oven uses impingement and microwave to cook food faster than traditional cooking methods. Air enters the cavity from the top and bottom using a single fan. Because of this design and to ensure uniformity of cooking, the oven must be operated only while the bottom jetplate is in place. While the bottom jetplate is removable for cleaning, it is not removable for cooking. Without the bottom jetplate in place, the oven will not deliver the proper cooking performance to either the top or bottom of the food item. Additionally, oven damage may result.

The sequence of the steps below may vary, and some may not apply.

Step 1: Turn the Oven On



Step 2: Select Cook Temperature



NOTE: The top temperature will allow you to cook items found in groups 1-8. The bottom temperature will allow you to cook items found in groups 9-16. If the temperatures are the same, this screen will be bypassed and access to all food items will be allowed.

Step 3: Warming Up



NOTE: When the oven is done warming up, it will “soak” for an additional eight minutes. “Soaking” ensures the cavity surfaces absorb enough heat so that cooking will not be affected. While the oven is soaking, the menu can be seen, but cooking will not be allowed until the timer reaches 0:00.

Step 4: Place Food in the Oven

 **WARNING:** Inside of oven and oven door are hot!

Step 5: Cook the Item

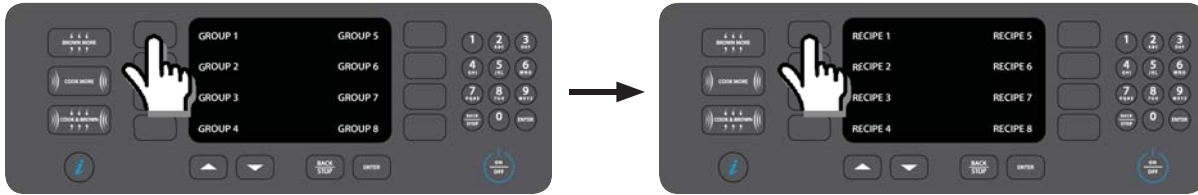

NOTE: Press Up or Down to view more groups (only available if all items have the same set temperature) or food items.

Step 6: Cooking



NOTE: To immediately terminate a cook cycle, press the Back/Stop key.

NOTE: If the oven door is opened during a cook cycle, the cycle will pause until the door is closed and ENTER is pressed to resume.

Step 7: Check/Remove Food from Oven



⚠ WARNING: Dish/inside of oven and door are hot!

Step 8: Brown More / Cook More / Cook & Brown

To cook an item longer than its original cook time, use one of the three keys on the left side of the keypad:

- Press “Brown More” if the outside of the food item requires browning or crisping.
- Press “Cook More” if the inside of the food item requires cooking.
- Press “Cook & Brown” if both the inside and outside of the food item require cooking.

Pressing one of these keys will cook the item for 20% of the last cook time selected. The minimum cook time is the less of 15 seconds or the entire original cook cycle. The maximum is one minute. The oven will cook at the settings listed below:

- Brown More: 100% air, 0% microwave
- Cook More: 10% air, 100% microwave
- Cook & Brown: 100% air, 100% microwave

Each additional key press while the oven is cooking adds 15 seconds of cook time to the “brown more,” “cook more,” or “cook & brown more” cycle, up to a maximum of five minutes.

NOTE: If a cook more option is selected, the oven will beep when the timer reaches zero, but no message will be displayed.

Step 9: Cooling Down



When finished cooking for the day, press the On/Off key to turn the oven off and begin cooling down.

*This page intentionally
left blank.*

Info Mode and Edit Mode

Info Mode

To access the Info Mode, press the “i” key when the oven is off or cooling down. There are two Info Mode screens – press the Up or Down key to switch between them.



Figure 5: Info 1 Screen



Figure 6: Info 2 Screen

Last Temperature Selected

From the Info 1 screen (Figure 5), the last temperature set point selected to cook is displayed in the top-left corner of the screen (SP=).

Serial Number

The oven serial number is shown on the Info 1 screen (Figure 5).

Menu Version

The oven menu version is shown on the Info 1 screen (Figure 5).

Firmware Version

The oven firmware version is shown on the Info 1 screen (Figure 5).

Cook Counter/Time Logs

From the Info 1 screen (Figure 5), press the key adjacent to “Counts Scroll”:

- Once to display the cook counter.
- Twice to display total cook time.
- Three times to display total magnetron time.
- Four times to display total “oven on” time.

Voltage - View Incoming

Incoming voltage is shown on the Info 1 screen (Figure 5).

Fault Log

From the Info 1 screen (Figure 5), select “Fault Log” to view fault counters for faults F1 through F8. To view F9 fault detail, press the Down key. To view time stamps of each fault occurrence, press the soft key adjacent to the fault code.

Service Numbers

From the Info 1 screen (Figure 5), select “Service Numbers” to view TurboChef contact information.

Test Mode

From the Info 2 screen, select “Test Mode” (see page 19) to test oven components. This mode should only be used by qualified service technicians, unless otherwise instructed by TurboChef.

Set Options

From the Info 2 screen (Figure 6), select “Set Options” to access the Options screen (Figure 7). When prompted, enter the password 9 4 2 8 and press the Enter key.



Figure 7: Set Options Screen

Cook More ON/OFF:

Figure 7. The Cook More option controls whether or not the three “cook more” keys function. This option must be enabled in order to cook an item beyond its original cook time (see page 11).

Edit Mode ON/OFF:

Figure 7. The Edit Mode allows the operator to change cook settings for each item, including item and group names. See page 17 for more details. Turning “Edit Mode” off will prevent the operator from changing menu settings.

Load Menu ON/OFF:

Figure 7, page 13. The Load Menu screen allows the operator to upload and/or download new menu settings from a USB drive or smart card. Turning “Load Menu” off will prevent access to the Load Menu screen when the operator is viewing the Info 2 screen. See page 15 for more details.

Network Setup:

Figure 7, page 13. Using Oven Connect (page 4) requires each oven to be networked. For help determining the correct network setup information, contact your network administrator.

From the network setup screen (Figure 8), the following information must be entered to configure the oven for networking:

- IP Address
- Mask
- Gateway (GW)
- Domain Name Server (DNS 1)
- Alternate Domain Name Server (DNS 2)



Figure 8: Network Settings Screen

Each number set can be edited in three-digit strings:

1. To edit the first string, press the Down key and then type in the first three digits.
2. Press the Down key again and enter the next three digits.
3. Repeat until all digits have been entered for each field.
4. Press “Save.”

If DHCP is turned on (top-left corner of screen), the oven will automatically be assigned an IP address when connected to a local area network (if an IP address is available). In most cases, TurboChef recommends leaving DHCP off to ensure the IP address on the oven does not change.

Auto Off - ON/OFF:

Figure 7, page 13. “Auto Off” is a feature that turns the oven off automatically at a specific time of day. To set the “Auto Off” time, see “Set Date/Time,” adjacent.

Auto On - ON/OFF:

Figure 7, page 13. “Auto On” is a feature that turns the oven on automatically at a specific time of day. To set the “Auto On” time, see “Set Date/Time,” below.

Demo Mode ON/OFF:

Figure 7, page 13. Demo Mode is a feature used to demonstrate the cooking features of the oven without turning on the heaters or microwave system. Demo Mode must remain off during regular operation.

Light Ring ON/OFF:

The light ring provides visual cues in regards to oven operation and how much cook time is remaining. To turn the light ring on or off, press the Down key from the Options screen and set the light ring as needed.

Set Date/Time

From the Info 2 screen (Figure 6, page 13), select “Set Date/Time” to set:

- Date and time of day
- Auto-on time
- Auto-off time

An accurate date and time of day are critical for using “auto-on” and “auto-off” (see above for details). They also help ensure the accuracy of diagnostics and fault condition reporting.

NOTE: The clock will not automatically update for Daylight Savings Time.



Figure 9: Set Date, Time, and Auto-On/Auto-Off Time Screen

NOTE: The clock is 24-hour (8:30 p.m. = 20:30).

NOTE: The oven will not retain the date and time if left unplugged for two or more weeks.

To set the date and time of day (Figure 9),

1. Use the keys to the left and right of the “date/time of day” field to move the cursor between digits.
2. Use the number keys to enter the month, day, and year, followed by the hour and minute.
3. Select “Save” to save your changes or press the Back/Stop key to cancel.

To set the auto-on or auto-off time (Figure 9, page 14),

1. Ensure the time of day is entered accurately.
2. Press the top-right soft key to toggle between temperatures 1 and 2. If two different temperatures are used for cooking, they must be set to different auto-on and auto-off times.
3. Use the keys to the left and right of the “auto on time” field or “auto off time” field to move the cursor between digits.
4. Use the number keys to enter the hour and minute for the oven to automatically turn on or off.
5. Select “Save” to save your changes or press the Back/Stop key to cancel.

Load Menu from USB or Smart Card

NOTE: To update the oven menu, you may need to verify that access to the Load Menu screen is turned on. See page 14, section “Load Menu ON/OFF” for details.

NOTE: Loading a menu from or saving a menu to USB will take a few seconds longer than smart card.

To load a menu to the oven,

1. From the Info 2 screen (Figure 6, page 13), select “Load Menu.”
2. Insert the USB device or smart card (Figure 10).

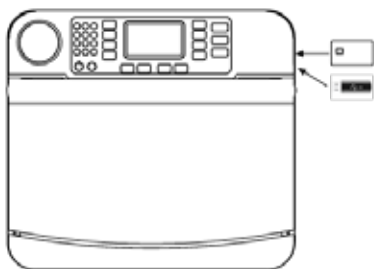

Figure 10: Smart Card / USB Slot Location

3. Load the menu (Figure 11):
 - a. For USB, select “Load from USB.”
 - b. For smart card, select “Load from Card.”
4. Verify the oven beeps and reads FINISHED.



Figure 11: Load Menu Screen: Load Menu Options

Save Menu to USB or Smart Card

NOTE: To save a copy of the oven menu, you may need to verify that access to the Load Menu screen is turned on. See page 14, section “Load Menu ON/OFF” for details.

To save a copy of the menu to a smart card,

1. From the Info 2 screen (Figure 6, page 13), select “Load Menu.”
2. Insert the USB device or smart card (Figure 10).
3. Save the menu (Figure 12):
 - a. For USB, select “Save to USB.”
 - b. For smart card, select “Save to Card.”
4. Verify the oven beeps and reads FINISHED.



Figure 12: Load Menu Screen: Save Menu Options

Sound Volume

From the Info 2 screen (Figure 6, page 13), select “Sound” to increase or decrease the oven sound volume.

Electrical Temperature

From the Info 2 screen (Figure 6, page 13), view the current temperature of the control board.

Reset the Oven

Resetting the oven is one way to clear an error message, should one occur. To reset the oven:

1. Return the oven to the cooling down or off screen. (Press the Back key if necessary.)
2. Hold the “i” key for 5 seconds.

Firmware Update

TurboChef may at some point recommend a firmware update. The update will make sure your oven is operating at its maximum efficiency, but will not affect cooking performance or menu settings.

⚠ CAUTION: The oven will not turn on if the firmware update is unsuccessful!

From the Oven Off screen,

1. Insert the smart card “1 of 3” (Figure 13).
2. When the oven is cooling down or off, press and hold the “i” key until the oven resets (approximately 5 seconds).
3. The oven will produce a series of short beeps. When the oven beeps one long tone, insert card “2 of 3.”
4. The oven will again produce a series of short beeps. When the oven beeps one long tone, insert card “3 of 3.”
5. The oven will again produce a series of short beeps. When the oven beeps one long tone, remove the smart card.
6. The oven will restart, indicating the update is complete.

If the update fails, the display will remain off and the oven will beep one long, low tone.

1. Unplug the oven and insert the first smart card.
2. Plug the oven back in.
3. Repeat steps 3-6 (adjacent).
4. If unsuccessful, contact TurboChef.

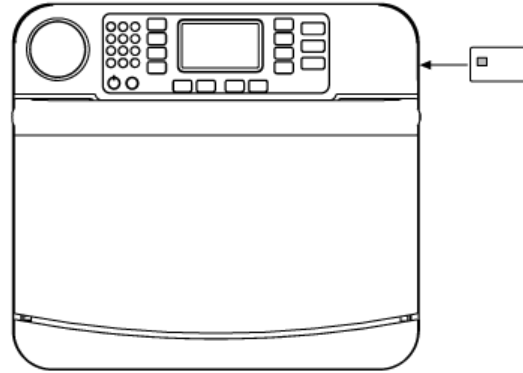

Figure 13: Smart Card Slot Location

Edit Mode

From Edit Mode, the operator can change menu settings and rename food groups and items.

To access the Edit Mode,

1. Enable it from the Options screen (Figure 7, page 13).
2. Press the On/Off key to return to the “Cooling Down” or “Off” screen.
3. Press the On/Off key again to enter Edit Mode.

In Edit Mode, editing can be performed on two screens. The first is explained on this page (Figure 14). It allows the operator to:

- Edit the set temperatures
- Select baking stone use
- Set the offset temperatures
- Select whether to edit temperature 1 food groups or temperature 2 food groups

The second screen is explained on page 18, and allows editing group and item names, as well as specific item settings.

Set Temperature Edit

The set temperature should never be changed to compensate for over-cooking or under-cooking. If recipe settings are not cooking as desired, consult your menu developer, authorized distributor, or TurboChef Customer Support.

To change a set temperature,

1. Place the oven in Edit Mode (see above).
2. Change the temperature:
 - a. Select “TEMP 1” to change the temperature for groups 1-8
 - b. Select “TEMP 2” to change the temperature for groups 9-16
 - c. Using the number keys, enter the new set temperature.
 - d. The temperature range is 300–540°F (149–282°C)
3. Press the Enter key to confirm the change, or the Back/Stop key to cancel.

Baking Stone Use YES/NO:

The “Stone” option on the Set Temperature screen should be set to:

- “Yes” if a baking stone is being used
- “No” if only a wire rack is being used

“Yes” increases the temperature of the bottom half of the oven for optimal cooking results when a stone is being used.

Bottom Temperature Offset

There are two Bottom Temperature Offset keys: one for each temperature. The bottom temperature offset keys allow the bottom heater to provide additional heat for increased browning.

To change a temperature offset,

1. Place the oven in Edit Mode (see adjacent).
2. Change the temperature offset:
 - a. Select “Bottom temp 1 Offset” to change the temperature offset for groups 1-8.
 - b. Select “Bottom temp 2 Offset” to change the temperature offset for groups 9-16.
 - c. Using the number keys, enter the new temperature offset.
 - d. The temperature range is 0-75°F (0-24°C).
3. Press the Enter key to confirm the change, or the Back/Stop key to cancel.

Select Groups and Items to Edit

Select “Edit temp 1 Groups” to edit recipe settings and/or group and item names for groups 1-8. Or, select “Edit temp 2 Groups” for groups 9-16. See page 18 for more information.



Figure 14: Edit Mode Screen 1: Temperature and Group Select

Recipe Edit

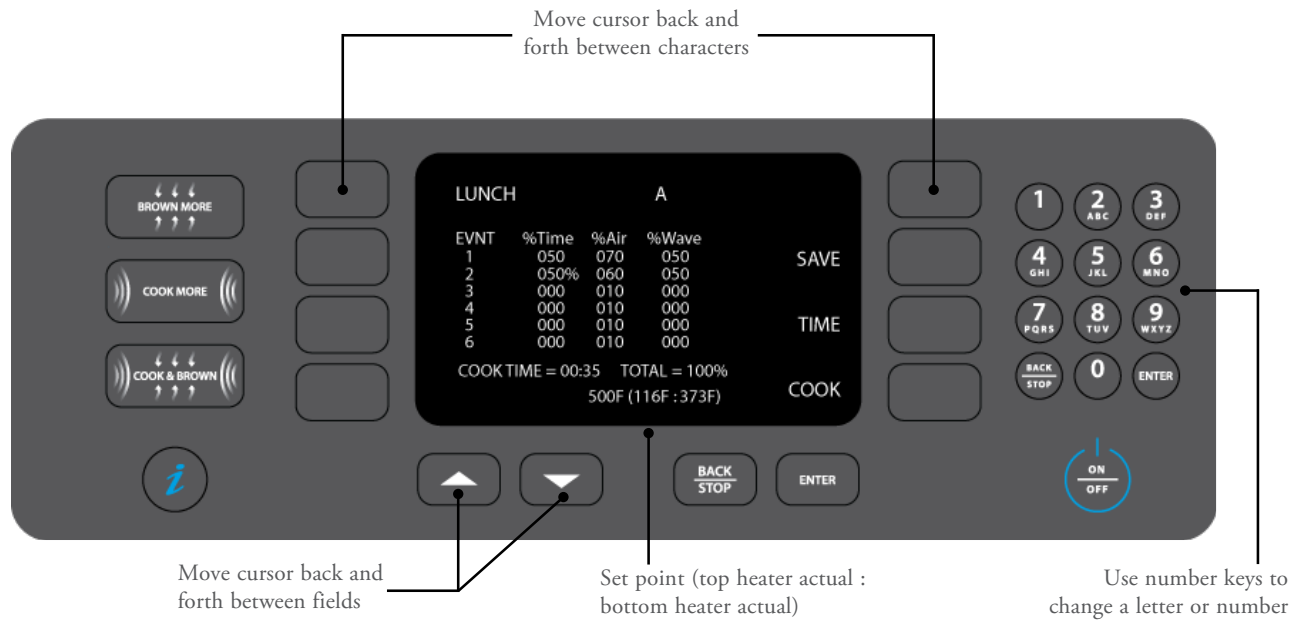

Figure 15: Edit Mode Screen 2: Recipe Edit

Go to the “Recipe Edit” screen (Figure 15) to change the food group name, food item name, and/or cook settings.

- Place the oven in Edit Mode (see page 17).
- Select “EDIT temp 1 GROUPS” or “EDIT temp 2 GROUPS.”
- Select the group that contains the item you want to edit.
- Select the food item you want to edit.
- Change the food group or food item name (Figure 15)
- Change the cook settings (Figure 15):
 - % Time can be set from 0-100% for each event. The sum of all events must be 100.
 - % Air determines the amount of airflow. The more air, the more the product will brown or crisp. % Air can be set from 10-100% in 10% increments.
 - % Wave determines the amount of microwave, and can be set from 0-100% in 10% increments. For example, 50% means the microwave system will remain on for five continuous seconds for every ten seconds during the cook cycle.
- Set the cook time. The maximum allowable cook time is 10:00.
- If desired, select “Cook” to perform a test cook.

NOTE: The oven may require additional warm-up time before a test cook can be performed.
- Select “Save” to save changes.
- When all editing is complete, return to the Options screen and turn off the Edit Mode (see page 13, section “Edit Mode ON/OFF”). This will allow access to the regular cook mode.

Test Mode

Test Mode

To access the Test Mode:

1. While the oven is off or cooling, press the “i” key.
2. Press the Down arrow key to view the Info 2 screen (Figure 6, page 13).
3. Select “Test Mode.”
4. When prompted, enter the password 9 4 2 8 and press the Enter key.

Test Mode is helpful for testing the oven circuits. By default, idle airflow is set to 40%.

Status Indicators

The status indicators are located at the bottom of the Test Mode screen:

- P = Primary switch (backlit = open)
- S = Secondary switch (backlit = open)
- M = Monitor switch (backlit = open)
- t = Magnetron thermostat (backlit = open)
- H1 = Top heater (backlit = off)
- H2 = Bottom heater (backlit = off)
- A = Air (blower motor) (backlit = off)
- W = Microwave (backlit = off)

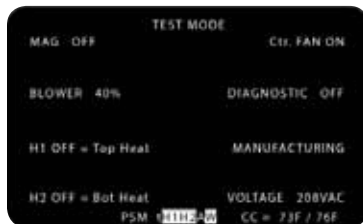

Figure 16: Test Mode Screen

In the Test Mode screen shown above:

- All three door switches (P, S, M) are closed.
- The top heater (H1) is off.
- The bottom heater (H2) is off.
- The blower motor (A) is on.
- The microwave circuit (W) is off.

Magnetron Test

To turn on the magnetrons, press and hold the key adjacent to “Mag” (Figure 17). To turn them off, release the key.



Figure 17: Test Mode: Magnetron Test

While holding the “Mag” key, measure the current transformer wire on the control board (Figure 18) for 13-15A (240 V) or 15-17A (208 V).

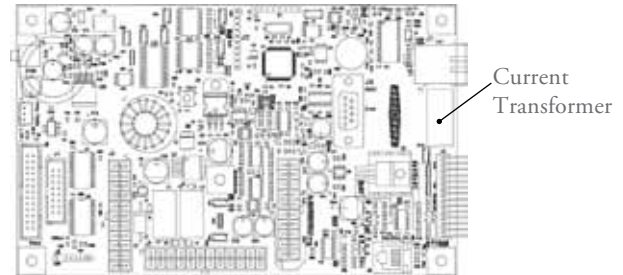

Figure 18: CT Location on Control Board

For more information on magnetron-related issues:

- See page 30 for additional testing options.
- See page 39 for F3 troubleshooting.
- See page 40 for F5 troubleshooting.

Blower Motor Test

Press the key adjacent to “Blower” (Figure 19) to increase the blower motor speed in 10% increments.



Figure 19: Test Mode: Blower Test

Test for voltage on the J1 and J2 connector:

1. Ground pin 5 of the J1 connector.
2. While pin 5 is grounded, check the terminals on the control wiring plug for 0-10 VDC across pins 1 and 2 of the J1 connector (Figure 20) while increasing the blower speed. The measurement should increase appx. 1 VDC for each 10% increase in blower speed, up to 100% (10 VDC), which is approximately 7,000 RPM.

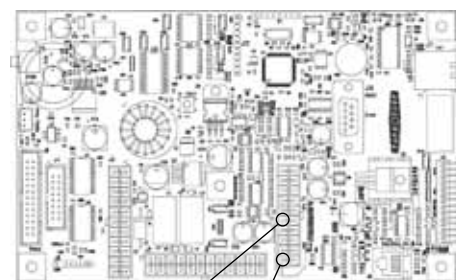

Figure 20: Blower Test Points on Control Board

Figure 20: Blower Test Points on Control Board

For troubleshooting an F1 fault, see page 37.

Top Heater Test

The top heater (H1) heats the airflow from the top of the cavity. To turn on the top heater, press and hold the key adjacent to “H1 = Top Heat.” To turn it off, release the key.



Figure 21: Test Mode: Top Heater Test

While holding the H1 key, the backlight behind the “H1” status indicator at the bottom of the screen should turn off. This means the top heater is on. If the top heater is not heating up while the H1 key is pressed, see pages 38 and 42 for troubleshooting.

Bottom Heater Test

The bottom heater is located beneath the bottom jetplate. To turn it on, press and hold the key adjacent to “H2 = Bot Heat.” To turn it off, release the key.



Figure 22: Test Mode: Bottom Heater Test

While holding the H2 key, the backlight behind the “H2” status indicator at the bottom of the screen should turn off. This means the bottom heater is on. If the bottom heater is not heating up while the H2 key is pressed, see pages 38 and 42 for troubleshooting.

Electrical Compartment (Ctl) Fan Test

To test the operation of the electrical compartment cooling fan, turn it on and off by pressing the “Ctl FAN” key. NOTE: All cooling fans should turn on in the [Encore 2](#) oven.



Figure 23: Test Mode: EC Fan Test

Diagnostic Mode

Diagnostic Mode is helpful for monitoring oven data while performing test cooks. When Diagnostic Mode is turned on, the oven will show the following information during cooking:

- Event currently being cooked
- Time left per event
- % wave and % air
- Top/bottom heater power sharing (Stone “No” = 50/50, Stone “Yes” = 30/70)
- Status indicators
- Group and recipe name
- Top/bottom heater temperature
- CC set point

To turn Diagnostic Mode on or off, press the key adjacent to “Diagnostic.” For normal oven operation, Diagnostic Mode should remain off.



Figure 24: Test Mode: Diagnostic Mode On/Off

Manufacturing Mode

Manufacturing Mode provides access to various tests and setup screens that are necessary for testing the oven at the time of manufacture. Some of these tests and setup screens are also useful when servicing the oven.

To access Manufacturing Mode, go into Test Mode (page 19) and press the key adjacent to “Manufacturing.”



Figure 25: Test Mode: Select “Manufacturing Mode”



Figure 26: Manufacturing Mode

Microwave Leakage Test

While in Manufacturing Mode (page 20), select “MW Leak Test” to begin a microwave leakage test. The oven will warm up to 500°F (260°C). When warmup is complete, insert the water load and follow the steps on page 26.



Figure 27: Microwave Leakage Test

Microwave Power Test

Do not use - for manufacturer use only.

Burn In

While in Manufacturing Mode (page 20), select “Burn In” to begin a 25-minute burn in. This feature helps ensure the reliability of test results by adequately warming the cavity walls. Burn in is not usually required unless instructed by TurboChef.



Figure 28: Burn In

Serial Number Edit

While in Manufacturing Mode (page 20), select “Serial No. Edit” to edit the serial number (may be required when replacing a control board).



Figure 29: Select “Serial Edit”

To edit the serial number (Figure 30):

- Use the number/letter keys to change a character. After one second, the cursor will advance to the next character.
- Select “<” to move the cursor back.
- Select “>” to move the cursor forward.
- Select “Save” to save your changes or “Cancel” to exit without saving.



Figure 30: Serial Number Edit Screen

Self Test

While in Manufacturing Mode (page 20), select “Self Test” to access the oven self test screen.



Figure 31: Select “Self Test”

From the Self Test screen (Figure 32):

- “Auto Test” will run all tests (listed below).
- “Door Test” will test the door switch sequence.
- “Blower Test” will increment the blower motor speed to verify response at each setting.
- “Mag Test” will test magnetron operation.
- “Heater Test” will test heater operation.

When each test completes, the oven will display PASS or FAIL.



Figure 32: Self Test Screen

Volt On

While in Manufacturing Mode (page 20), press the key adjacent to “Volt” to change whether or not the voltage is displayed on the Info 1 screen (page 13).



Figure 33: Volt On/Off

NOTE: The voltage display on the Info 1 screen is for detecting 208 or 240 VAC. It is not an accurate voltage input measure for installations that do not require voltage detection. For international installations, the “Volt” option should remain off.

Erase/Default Oven Settings

CAUTION: Settings cannot be retrieved once an erase option is confirmed.

While in Manufacturing Mode (page 20), select “Erase/Default” (Figure 34) to access the “Erase” screen (Figure 35).



Figure 34: Select “Erase/Default”

There are two options on the “Erase” screen:

- Erase Counters and Fault Logs
- Complete Erase: This option will erase counters, fault logs, menu settings, temperature settings, serial number, date, and time. It will also default all oven options except “Load Menu” to OFF (see page 13, section “Set Options”).



Figure 35: Erase Screen

Changing Temperature Measurement: F or C

While in Manufacturing Mode (page 20), press the bottom-right soft key (Figure 36) to set the temperature measurement to Fahrenheit or Celsius.



Figure 36: Change Temperature Measurement

Oven Systems

Impingement System

The impingement system rapidly heats, filters, and recirculates air into the cook cavity.

This section contains information about the following components:

- Blower motor
- Blower motor speed controller (BMSC)
- Heater - top
- Heater - bottom
- High-limit thermostat
- Jetplate - bottom
- RTD - top and bottom
- Solid state relay (K4/K5 - Heaters)

For information on accessing and removing parts, see the Appendix.

Blower Motor

The blower motor is a brushless AC-switch reluctance type and spins clockwise. Its top speed is 7,100 RPM at 1 HP, and it is controlled by a proprietary controller (see below).

Blower Motor Speed Controller (BMSC)

The motor controller is proprietary and will only operate the motor described above. It is controlled via 0-10 VDC speed command from the control board and can be tested in Test Mode (see page 19).

Heater - Top

The top heater is an open-coil heater rated at 3,300 watts at 208 VAC, with a resistance of 13 Ω . The top heater is controlled by K5 of the K4/K5 solid state relay. For testing instructions, see page 20.

Heater - Bottom

The bottom heater is a sheathed-style heater rated at 3,000 watts at 208 VAC, with a resistance of 14.4 Ω . The bottom heater is controlled by the K4 of the K4/K5 solid state relay. For testing instructions, see page 20.

High Limit Thermostat

The high limit thermostat is a 250 VAC, 3-pole, manual-reset thermostat with a trip point of 572°F (300°C). The thermostat interrupts power to the bottom or top heater in the event of an abnormal condition. Reset the high-limit thermostat by pressing the reset button on the back oven wall, near the power cord.

Jetplate - Bottom

The bottom jetplate channels air from the blower motor into the cavity. It is removable for cleaning.

NOTE: The top jetplate is not removable.

RTD - Top and Bottom

One RTD measures the temperature of the top heater, and another RTD measures the temperature of the bottom heater. If the display reads “999°F/C”, at least one RTD is open, resulting in an F7 fault. See page 41 for troubleshooting.

Testing Procedure:

1. Disconnect the RTD from the control harness (see page 48 for Encore and page 62 for [Encore 2](#)).
2. Place the RTD in ice water for two minutes.
3. Take a resistance reading of the RTD.
4. If RTD resistance is not 100 Ω (+/- 2 Ω), the RTD is defective and must be replaced.

Solid State Relay - K4/K5 Heaters

The solid state relay is a 240 VAC, dual 40-amp relay. K4 switches power to the bottom heater, and K5 switches power to the top heater.

Troubleshooting

The following faults may occur in relation to the convection system:

- F1: Blower (see page 37)
- F2: Low Temp (see page 38)
- F6: EC Temp (see page 41)
- F7: Thermo (see page 41)
- F8: Heat Low (see page 42)

The following cooking performance issues may occur in relation to the convection system:

- Food not cooking properly (see page 45)

Oven Door

This section contains information about the following components:

- Oven door
- Interlock switches
- Relay (K3 - Monitor)

This section also contains procedures for:

- Removing/reinstalling the oven door
- Adjusting the oven door
- Adjusting the primary, secondary, and monitor switches
- Measuring RF leakage for microwave safety

For information on accessing and removing parts, see the Appendix.

The oven door assembly consists of a shunt plate, skin, and handle. Each of these items can be serviced and replaced independently.

 The proper fit and adjustment of the oven door is essential for safe and reliable oven operation.

Removing/Reinstalling the Oven Door

To remove or reinstall the oven door, follow the steps below. For illustrations, see page A-8 for the Encore and page A-24 for the [Encore 2](#).

1. Ensure the oven has cooled to 150°F (66°C).
2. Open the oven door to its full open position and insert rivets, screws, or nails (Figure 37) to hold the hinges in the open position.

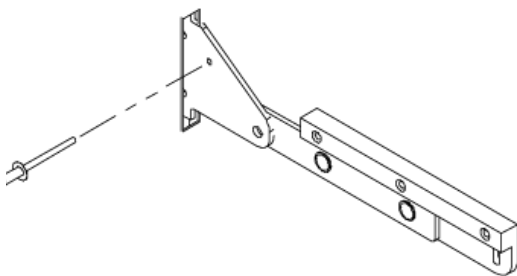



Figure 37: Use Rivet, Screw, or Nail to Hold Hinge Open

3. Remove the plastic caps and using a $5/16$ " hex driver, remove the hex cap screws (2 per side). This will allow the hinge blocks to be removed together with the door.

4. Carefully remove the oven door by pulling it away from the oven.
5. Reinstall (or replace) the door by securing it via the hex screws, verifying that the door is parallel to the oven frame. If it is not parallel, adjust the door (see below).
6. From Test Mode (page 19), check the status indicators "P" "S" and "M" to verify the switches are backlit (door closed) and not backlit (door open) at the proper times. If necessary, adjust the switches (page 25).
7. Complete a microwave leakage test (page 26).

Adjusting the Oven Door

 **WARNING:** This procedure is performed while the oven is hot. To avoid burns, be careful when adjusting the door.

1. Open the door and remove the plastic caps.
2. Loosen the two hex screws and close the door.
3. Tap the center of the door to allow the door and frame to align properly. The hinge springs will pull the door to the frame; do not push on either side, rather only in the center.
4. Tighten the screws and reinstall the caps.
5. Plug in the oven and perform a microwave leakage test (see page 26).

Critical Adjustment Notes

If the top or bottom of the door is rotated away from the oven cavity frame, the door is misaligned.

Corrective Action

1. Loosen the hex screws and push the door towards the flange.
2. The hinge springs will naturally pull the door to the flange. Tap the center to ensure a level surface and proper seal.

NOTE: Do not push one end at a time, which could cause the opposite end to lift away from the flange.

3. Re-tighten the hex screws.
4. Pull the door open only 0.25" (6 mm) and let go of the handle.

Continued on page 25.

The door must completely snap shut on its own. If the door sticks or force is needed to finish closing it, it is out of adjustment.

⚠ WARNING: Perform a microwave leakage test (page 26) after adjusting the oven door.

Interlock Switches

The primary, secondary, and monitor interlock switches engage and disengage in sequence to ensure a proper seal. When the door is opened, the switch sequence is P, S, M. Subsequently, the sequence is M, S, P when the door is closed.

Relay - K3 Monitor

The K3 relay is a 240 VAC, 24 VDC coil, 20 amp, sealed dual-pole relay. It shorts L1 and L2, which blows the F3 fuse if the monitor switch opens before the primary or secondary switches.

Adjusting the Primary, Secondary, and Monitor Switches

⚠ WARNING: This procedure is performed while the oven is hot. To avoid burns, be careful when adjusting the switches.

Use the following procedure to adjust the primary, secondary, and monitor switches. The secondary switch is located on the left side hinge assembly and the monitor switch is located on the right side hinge assembly. The primary switch is located on the upper-left corner of the oven and utilizes an actuator (attached to the door) and toggle assembly (attached to the chassis) to engage (Figure 38). For switch assembly details, see page A-8 for the Encore and page A-24 for the [Encore 2](#).

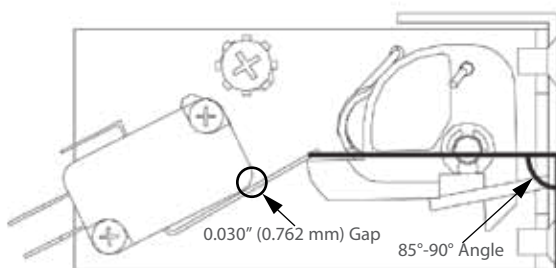

Figure 38: Switch Detail and Proper Alignment

1. Ensure the oven has been at operating temperature for at least fifteen minutes.
2. If adjusting the primary switch, confirm the primary switch's latch toggle is in the correct position (Figure 38).
 - a. Visually inspect the latch toggle position and verify it is angled at no less than 85° and no more than 90° in reference to the front flange (oven face). See Figure 38.
 - b. If the toggle is less than 85° or greater than 90°, correct the toggle's position by installing a spacer/shim (the more distance from the flange, the less angle on the toggle):
 - [NGC-1169-1](#): Shim, 0.030" (0.762 mm)
 - [NGC-1169-2](#): Shim, 0.045" (1.143 mm)
 - c. Verify the position of the toggle by opening and closing the oven door several times.
3. Adjust the switch(es):
 - a. Enter Test Mode (page 19).
 - b. Open the oven door and view the status indicators at the bottom of the screen to verify P, S, and M disengage in sequence.
 - c. Close the oven door and verify M, S, and P engage in sequence.
 - d. If the switches do not engage or disengage in sequence, close the door and adjust the necessary switch(es) by loosening the two #4-40 screws and #8-32 screw until the proper sequence is achieved.

NOTE: DO NOT allow the switch paddle to rest on the body of the switch in the closed door position. The final adjustment requires a minimum of a 0.030" (0.762 mm) gap to avoid over-travel and bent/damaged switches.

4. Open and close the door several times to verify the switch gap.
5. Energize the microwave system and open the oven door.
6. Verify the W indicator is backlit, meaning the microwave system turns off when the door is open.
7. Perform a microwave leakage test (page 26).

Measuring RF Leakage for Microwave Safety

⚠ WARNING: This procedure requires work with hot surfaces and water loads. To avoid burns, be careful when testing.

An RF (microwave) leakage test must be performed at the conclusion of the following service tasks:

- Door removal, replacement and/or adjustment
- Waveguide removal and/or replacement
- Magnetron removal and/or replacement
- Door switch adjustment and/or replacement

⚠ WARNING: If the unit fails the microwave leakage test (leakage greater than $5\text{mW}/\text{cm}^2$), the oven must be taken out of service immediately until the defect is corrected. In addition, the CDRH Regulation 21 Subpart C, 1002.20 requires that leakage readings of over $5\text{mW}/\text{cm}^2$ must be reported to the manufacturer.

To measure RF leakage,

1. Turn the oven on and allow it to warm up to the set temperature (approximately 15 minutes if the oven starts cold).
2. Once the oven has warmed up, place the oven in Test Mode (page 19). From Test Mode, select Manufacturing Mode (page 20).
3. From the Manufacturing Mode screen, select “MW Leak Test” (page 21) and follow the instructions on the screen (also detailed in the following steps).
4. Place a water load into the cook cavity. The water load must conform to the following specifications:
 - Volume: $275\text{ ml} \pm 15\text{ ml}$ (1 cup/8 fl oz)
 - Temperature: $68^\circ\text{F} \pm 9^\circ\text{F}$ ($20^\circ\text{C} \pm 5^\circ\text{C}$)
 - Vessel: Low form, 600 ml beaker with an inside diameter of approximately 3.35” (85 mm) and made of Pyrex or equivalent.
5. Close the oven door and press the Enter key. The microwave system will turn on.
6. Measure microwave emission around the door as shown in the adjacent illustration, moving the meter sensor at 0.5 inches/second.

7. As microwave leakage is observed while moving the sensor, note any meter spike areas that come close to $5\text{mW}/\text{cm}^2$ for later re-measurement.
8. Replace the water load every 60 seconds until the test is completed, and also after scanning the door.
9. Close the oven door and return the meter probe to any “meter spike” areas and allow the probe to remain in the “spike” area for 17 seconds. Note the highest reading obtained.

NOTE: There may be several places on the door where this procedure needs to be done. If so, start out with a fresh water load each time a new area is measured, or if measurement of an area takes longer than 60 seconds.

10. After each test is complete, open the oven door and dispose of the hot water.

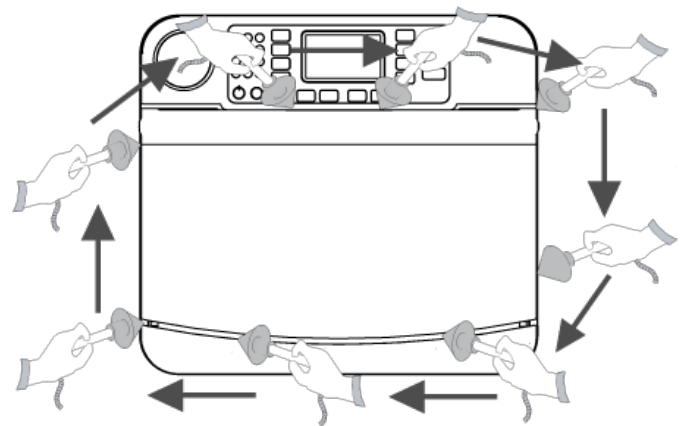

Figure 39: Measure for Microwave Leakage

Troubleshooting

The following faults may occur in relation to the oven door:

- F4: Monitor (see page 40)

The following issues may occur in relation to the oven door:

- “Cook Door Open” message when door is closed (see page 43)

Microwave System

The oven employs left and right microwave systems. In the case of an over-current situation, the F3 fuse (20 amp) will blow, shutting off both systems immediately.

This section contains information about the following components:

- Capacitors
- Filament transformers
- High-voltage transformers
- High-voltage diodes
- Magnetrons
- Magnetron cooling fans
- Magnetron thermostats
- Relay (K1 - Filament)
- Relay (K2 - Anode)
- Relay (K7 - Encore: Magnetron cooling fans / [Encore 2](#): All cooling fans)
- Waveguides

This section also contains procedures for:

- Testing a capacitor (page 27)
- Wiring the filament transformers (page 27)
- Testing a filament or high-voltage transformer (page 28)
- Wiring the high-voltage transformers (page 28)
- Testing a high-voltage diode (page 29)
- Testing a magnetron for an open/shorted filament (page 30)

For information on accessing and removing parts, see the Appendix.

Capacitors

- Capacitor rating is 0.91 μ F, 2500 VDC for all 60 Hz installations (except Japan).
- Capacitor rating is 1.15 μ F, 2500 VDC for all 50 Hz installations.
- Capacitor rating is 0.85 μ F, 2500 VDC for 60 Hz Japan installations.

Testing a Capacitor



DANGER: Never attempt any measurement of the capacitors while they are enabled. Lethal voltage will be present. Measure only in compliance with these procedures.

1. Disconnect the oven from the power source.
2. Fully discharge the capacitor.
3. Isolate the capacitor from the circuit.
4. Check for an open or shorted capacitor by placing ohmmeter leads between the capacitor terminals:
 - Escalating ohm readings = capacitor OK
 - Constant infinite resistance = capacitor open
 - Constant very low resistance = capacitor shorted
5. If the capacitor is not open or shorted, set the meter to measure capacitance and again place the leads between the capacitor terminals. The meter reading should equal the label value, plus or minus 10%. If not, replace the capacitor.

Filament Transformers

For better operation and reliability, the oven utilizes separate transformers in order to preheat the magnetron filament.

The filament transformers are energized for approximately five seconds prior to energizing the microwave circuit via the high-voltage transformers. When in operation, the filament transformers supply approximately 3.15 VAC at 10 amps to each magnetron filament. The filament transformers are controlled via the K1 relay.

Wiring the Filament Transformers

The installation of filament transformers is straightforward. Filament transformers are wired in-phase and in-line. Refer to the schematic detailing proper wiring (page 48 for Encore and page 62 for [Encore 2](#)).

To verify correct wiring (North America), measure the voltages between terminals 1 & 2 and 1 & 3 on FT1 and FT2. The voltages must be 208 and 240 VAC respectively. See the table on page 29 for resistance values.

NOTE: The orange wire always goes to terminal 3 on US models.

To verify correct wiring (International), measure the voltage between the taps on FT1 and FT2. The voltage must be 230 VAC. See the table on page 29 for resistance values.

High-Voltage Transformers

The high-voltage transformers are ferro-resonant, which limits faulty currents and minimizes magnetron power changes due to input voltage changes. The high-voltage transformers supply the high voltage for the voltage doubler circuit. They are controlled via the K2 relay.

Wiring the High-Voltage Transformers

 **DANGER:** Never attempt to wire or measure the secondary voltage values of the high-voltage transformers. Lethal voltage will be present.

The proper reinstallation of a high-voltage transformer is critical. Upon removing a high-voltage transformer, make sure to note where each wire was installed. Refer to the oven schematic (page 48 for Encore and page 62 for [Encore 2](#)) for wiring detail.

As shown in the schematic, transformers are installed mirror opposite and wired 180° out-of-phase. It is essential for longevity that the high-voltage transformers remain 180° out-of-phase. This can be checked by placing a volt meter across terminals T1-1 and T2-1 (primary voltage).

With the microwave system energized, the volt meter will read the incoming voltage (different readings for different installations). If the meter reads 0 VAC, the high-voltage transformers are most likely wired in-phase (incorrectly). As a last check, energize the microwave system and verify the voltages between the taps on each high-voltage transformer.

The wiring issue must be corrected prior to returning the oven to service, as the voltages must be:

- NORTH AMERICA: 208 VAC between 1 & 2 and 240 between 1 & 3.
- INTERNATIONAL: 230 VAC

NOTE: The orange wire always goes to terminal 3 on US models.

Testing a Filament or High-Voltage Transformer

 **DANGER:** Never attempt to measure the secondary voltage values of the HV transformers. Lethal voltage will be present.

1. Disconnect the AC power source and discharge the high-voltage capacitors.
2. Disconnect all the wires in question going to and from the transformer.
3. Use an ohmmeter to check the resistance of the primary and secondary winding. Refer to the table on page 29 to determine if the transformer is OK. If the resistance is different than the values provided in the table, replace the transformer.

High-Voltage Diodes

The high-voltage diode (Figure 40) is assembled by connecting several 1000-1500 volt semi-conductor diodes in a series to increase the reverse voltage capability. In the circuit, the high-voltage diode conducts to prevent the filament voltage from becoming positive, thus as the high-voltage winding of the transformer goes to a peak of 2400 volts, the high-voltage capacitor is charged to 2400 volts.

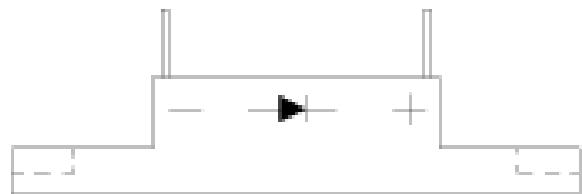

Figure 40: High Voltage Diode

When the high-voltage winding starts to go toward negative, the high-voltage diode becomes non-conducting with the charged high-voltage capacitor in series with the high-voltage winding. When the transformer gets to its negative peak of -2400 volts, the voltage applied to the anode body of the magnetron through the ground path of the oven is -4500 volts. The high-voltage diodes are rated at 16 kVDC.

High Voltage Transformers	Primary Voltage, Frequency, Taps, and Resistance	Secondary Taps and Resistance
NGC-3062-1	208 VAC, 60 Hz, 1 & 2, 0.819–1.001 Ω 240 VAC, 60 Hz, 1 & 3, 0.972–1.188 Ω	4, Ground, 53.60–65.52 Ω
NGC-3062-2	230 VAC, 50 Hz, 1 & 2, 0.972–1.188 Ω	3, Ground, 57.52–70.30 Ω
Filament Transformers	Primary Voltage, Frequency, Taps, and Resistance	Secondary Taps and Resistance
NGC-3061-1	208 VAC, 60 Hz, 1 & 2, 17.49–21.37 Ω 240 VAC, 60 Hz, 1 & 3, 20.61–25.19 Ω	4, 5, very low resistance - if reading is open, transformer has failed.
NGC-3061-2	230 VAC, 50 Hz, 1 & 2, 18.99–23.21 Ω	4, 5, very low resistance - if reading is open, transformer has failed.

Testing a High-Voltage Diode



DANGER: Never attempt to measure high voltage directly. Death or serious injury could result.

1. Disconnect the oven from the power source.
2. Fully discharge the capacitors.
3. Connect the voltage meter in series with high-voltage diode.
4. Using a multimeter set to DC voltage, connect one meter lead to one side of a 9-volt battery and the other lead to one side of the high-voltage diode.
5. Connect the other side of the 9-volt battery to the other side of the high-voltage diode. DC voltage should be present on the meter in only one direction.
6. Switch the meter leads on the high-voltage diode, which will cause the opposite reading to be visible. Depending on the voltage of the battery, voltage between 5-7 VDC should be present in only one direction and 0-0.1 VDC in the other direction.

Magnetrons

Magnetrons supply the RF energy at 2.45 GHz and begin to oscillate when they are supplied with approximately 4.1 kVDC at approximately .350 mA. During operation, each magnetron will output a nominal 1 kW of power.

Perform a microwave leakage test (page 26) after installing a new magnetron or reinstalling an old one.



CAUTION: Do not allow debris to enter the waveguides when servicing the magnetrons.

Magnetron Cooling Fans

The magnetron cooling fans (outer fans on the back panel) are actuated by the K7 relay when the magnetrons are in operation, and remain on for four minutes and fifteen seconds after the magnetrons turn off. They operate at:

- 208/240 VAC (60 Hz with voltage sensing)
- 220 VAC (60 Hz with no voltage sensing)
- 230 VAC (50 Hz installations)

NOTE: In the [Encore 2](#), the magnetron cooling fans are actuated by the K7 relay when the EC temperature exceeds 120°F (49°C), regardless of magnetron operation.

Magnetron Thermostats

The magnetron thermostats are “open-on rise.” They are designed to open at 270°F (132°C), which triggers an F5 fault.

NOTE: The magnetron thermostats are wired in series. If one opens, the control will switch off both magnetrons until the open thermostat closes. The thermostats are self-resetting.

Testing a Magnetron for an Open/Shorted Filament

⚠ DANGER: The only safe way to test a magnetron is by a resistance test of its filament. Never attempt to measure the magnetron using any other method while the microwave system is on. Death or serious injury will occur.

1. Disconnect the AC power source and discharge the high-voltage capacitors.
2. Isolate the magnetron from the circuit by removing the wires from the F and FA terminals (Figure 41).
3. An ohmmeter connected between the filament terminals (F, FA) should indicate a reading of less than 1 Ω (Figure 41).
4. A continuity check between either filament terminal and the magnetron chassis should indicate an infinite resistance (open).

⚠ CAUTION: Do not allow debris to enter the waveguides when servicing the magnetrons.

Relay - K1 Filament

The K1 relay is a 240 VAC, 24 VDC coil, 20 amp, sealed double-pole, double-throw relay. It switches power to the filament transformers.

Relay - K2 Anode

The K2 relay is a 240 VAC, 30 amp, double-pole, double-throw, 24 VDC relay coil. It switches power to the high-voltage transformers.

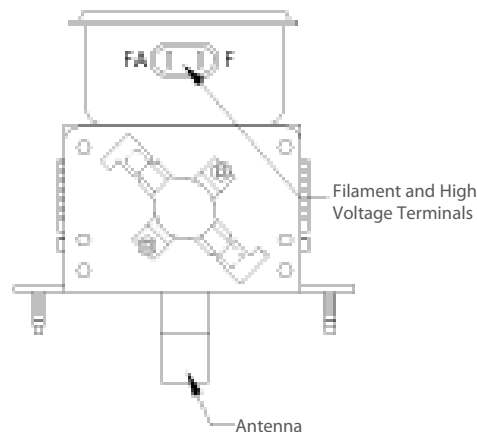

Figure 41: Magnetron Detail

Relay - K7 Encore: Magnetron Cooling Fans / Encore 2: All Cooling Fans

The K7 relay is 240 VAC, 24 VDC coil, 20 amp, sealed single-pole relay. It switches power to the magnetron cooling fans when the magnetron filaments are actuated. Power is switched off after four minutes and fifteen seconds.

NOTE: The four-minute, fifteen-second timer starts over each time the magnetron filaments are actuated.

NOTE: In the [Encore 2](#), the magnetron cooling fans are actuated by the K7 relay when the EC temperature exceeds 120°F (49°C), regardless of magnetron operation.

Waveguides

The waveguides channel microwaves into the cook cavity. If debris or contamination gets into the waveguides, the life of the magnetrons may be shortened. Be careful to not allow debris into the waveguides when servicing the magnetrons.

Troubleshooting

The following faults may occur in relation to the microwave system:

- F3: Magnetron Current Low (see page 39)
- F5: Magnetron Over Temperature (see page 40)

The following issues may occur in relation to the microwave system:

- Electrical component failure (blank or scrambled display, damaged control board, etc.)
- Food not cooking properly (see page 45)

Control System

This section contains information about the following components:

- Control board
- Display
- Ethernet extension cable
- Keypad
- LED light ring
- Speaker
- USB/Smart card reader

For information on accessing and removing parts, see the Appendix.

Control Board

The control board signals each oven component based on commands from the keypad. 24 VDC can be measured at pin 2 of the J7 connector to confirm control voltage is being applied (see page 48 for the Encore and page 62 for the [Encore 2](#)).

Before replacing a control board, determine if the oven is connected to the store's network. If so:

1. Record the oven's network information:
 - a. While the oven is off or cooling down, press the "i" key.
 - b. Press the Down Arrow key to view the Info 2 screen.
 - c. Select "Set Options."
 - d. Select "Network Setup."
2. Record the IP, Mask, GW, DNS1 and DNS2 numbers.
3. Re-enter these numbers after replacing the control board.

If the control board is damaged to the point of not allowing access to the Network Setup screen, have the store contact its Oven Connect administrator to obtain the proper network settings.

Display

The TFT display is the primary user interface. Both 24 VDC and 5 VDC are supplied from the control board through the 3-pin power cable. 24 VDC is used for the backlighting and 5 VDC is used for the logic systems.

Ethernet Extension Cable

The ethernet extension cable exits the oven at the back panel and allows the oven to be connected to a local network, in case the customer desires remote programming and oven diagnostics reporting.

Keypad

The keypad is an 10 x 10 matrix membrane switch. For details on key functions, see page 9.

LED Light Ring

The LED light ring provides visual cues in regards to oven operation and counts down the final 30 seconds of each cook cycle.

Speaker

The speaker provides audible feedback to the oven operator whenever a key is pressed or a task (such as a cook cycle) is completed.

USB/Smart Card Reader

The USB/smart card reader allows the oven operator to load menus and firmware updates to and from a USB thumb drive or smart card. For instructions, see page 15.

Troubleshooting

The control system could potentially be related to the cause of any fault (see pages 35-42 for detailed fault troubleshooting).

The control system might also be related to any issue diagnosed in the section "Non-Fault Code Troubleshooting" on pages 43-46.

Power Components

This section contains information about the following components:

- Electrical compartment cooling fan
- Electrical compartment thermostat
- Electrical compartment thermocouple
- EMI filter
- Fuses
- Power supply, 24 VDC
- Relay (K6 - Voltage)
- Relay (K7 - EC Cooling Fan - [Encore 2](#) Only)
- Relay (K8 - EC Cooling Fan - [Encore](#) Only)
- Voltage sensor
- Wire harnesses

For information on accessing and removing parts, see the Appendix.

Electrical Compartment Cooling Fan

The oven has three fans across the top of the back panel. The center fan cools the electrical compartment. It is actuated by the cooling fan thermostat when the temperature of the electrical compartment reaches 120°F (49°C).

Electrical Compartment Thermostat

The [Encore](#) cooling fan thermostat, located on the RHS electrical panel, actuates the electrical compartment cooling fan via the K8 cooling fan relay. The [Encore 2](#) cooling fan thermostat, located on the top electrical panel, actuates the electrical compartment cooling fan via the K7 cooling fan relay.

Electrical Compartment Thermocouple

The electrical compartment thermocouple is part of the control board and measures the temperature of the electrical compartment. If it is above 158°F (70°C), an F6: EC TEMP fault will display. The control board checks the electrical compartment temperature once every 60 seconds.

EMI Filter

The EMI filter helps suppress the amount of RF interference emitted by the oven.

Fuses

The F1 and F2 fuses are 12-amp, ATMR, class CC. The F3 fuse is 20-amp, ATMR, class CC. The F1 fuse (via blue wire) and F2 fuse (via brown wire) are designed to blow if an over-current situation is

encountered by the motor controller, any cooling fan, either filament transformer, or power supply.

The F3 fuse is designed to blow in case of an over-current situation encountered by the microwave system (magnetron, high-voltage transformer, diode, capacitor). It is also designed to blow if the monitor switch opens before the primary or secondary switch.

Power Supply

The power supply outputs 24 VDC at 40 watts to the control board and relays.

Relay - K6 Voltage

The K6 relay is a 240 VAC, 30 amp, three-pole, double-throw, 24 VDC relay coil. Operational in North America only, it switches between 208 and 240 VAC on the HV transformer and filament transformer taps (depending on incoming voltage). Through the voltage sensor, the oven defaults to the 240V position and switches to 208 if less than 222 volts is detected. 230V/400V international ovens and all Japan models utilize the normally-closed (N.C.) contacts of the relay (default position) to power the microwave transformers.

Relay - K7 [Encore](#): Magnetron Cooling Fans / [Encore 2](#): All Cooling Fans EC Cooling Fan

The K7 relay is a 240 VAC, 24 VDC coil, 20 amp, sealed double-pole, double-throw relay. It switches power to the center cooling fan when the electrical compartment thermostat detects 120°F (49°C). See page 29 for more details.

Relay - K8 EC Cooling Fan ([Encore](#) only)

The K8 relay is 240 VAC, 24 VDC coil, 20 amp, sealed single-pole relay. It switches power to the center cooling fan when the electrical compartment thermostat detects 120°F (49°C).

NOTE: The [Encore 2](#) EC cooling fan is actuated by the K7 relay; see above.

Voltage Sensor

For North America models only. Voltage selection is completed at the time of manufacture; however, if incoming voltage for the store is different than the preset voltage, the operator will be required to select either 208 or 240 after turning on the oven. The correct voltage will be enlarged on the screen, identifying which option to select.

Wire Harnesses

The wire harnesses distribute power to the oven's electrical components. For oven schematic and wire harness drawings, see pages 47-59 for the Encore, and pages 61-72 for the [Encore 2](#).

Troubleshooting

The power components could potentially be related to the cause of any fault (see pages 35-42 for detailed fault troubleshooting).

The power components might also be related to any issue diagnosed in the section "Non-Fault Code Troubleshooting" on pages 43-46.

Filtering System

This section contains information about the following components:

- Catalytic converter
- Air filter
- Vent catalyst

Catalytic Converter

The catalytic converter, a VOC type catalyst, is located behind the inside cook cavity wall and is responsible for cleaning the recirculating airflow. The catalyst functions by substantially lowering the combustion temperature of grease entrained in the air path to approximately the same temperature of the airflow; thus the grease burns and breaks down into CO₂ and H₂O as it passes through the catalytic converter. The catalyst will operate most efficiently at temperatures above 475°F (246°C).

The catalyst material is very sensitive to certain chemical compounds. Irreversible damage can occur if the catalyst is exposed to cleaning chemi-

cals containing phosphates, NaOH, silicates, Na and Potassium Salts. These chemicals are found in most commercial degreasers and cleaners; therefore, only TurboChef Oven Cleaner should be used.



CAUTION: Clean the catalytic converter with TurboChef Oven Cleaner and rinse thoroughly with distilled water. Let the catalytic converter air dry before reinstalling. If TurboChef Oven Cleaner is not available, use only distilled water.

Air Filter

The filter is located on the back of the oven. It helps prevent debris from getting into the electrical compartment through the cooling fans. The filter requires scheduled maintenance and occasional replacement, as it must be kept clean and in good working condition to ensure proper air circulation to the electrical components of the oven. See page 5, step 5 for details.

Vent Catalyst

In addition to the main catalytic converter, the oven contains a secondary catalyst in the vent tube path. This catalyst further assists in the breakdown of grease and particulate matter before the excess air enters the atmosphere.

Troubleshooting

The following issues may occur in relation to the filtering system:

- F9: CC Temp (if the catalyst is clogged with grease and debris - see page 42)
- Fire in the cook cavity (if catalytic converter is clogged and oven is not regularly cleaned).
- Steam present at the top of the oven door or when the door is opened (if vent catalyst is clogged or vent cover is installed upside down).
- Electrical component failure (if filter is not present or is clogged).
- Undesirable flavor transfer.
- Undesirable odors.

*This page intentionally
left blank.*

Troubleshooting

Overview of Troubleshooting

This section contains information on the following:

- Fault code descriptions
- Fault code troubleshooting
- Non-fault code troubleshooting

For information on accessing Test Mode, see page 19. For information and illustrations on replacing components, see the Appendix.

Fault Code Descriptions

To view the fault log:

1. While the oven is cooling down or off, press the “i” key to access the Info Mode.
2. From the Info 1 screen (Figure 5, page 13), select “Fault Log.”

NOTE: Press the Down key to view the F9 fault.

3. To view time stamps of each fault occurrence, press the soft key adjacent to the fault code.

F1: Blower Running Status Bad

This fault is displayed when the motor controller indicates no running status.

The motor and motor controller are monitored continuously in all modes with special handling in Test Mode (page “Test Mode” on page 19). If a fault is detected, the oven will stop cooking and go to the “Cooling Down” screen while flashing “F1: Blower.”

Upon turning on the oven, the control will attempt to restart the motor. If the restart is successful, the fault message will be cleared from the display. The fault message is also cleared at the onset of cooking or when the blower motor is tested in Test Mode (page 19, section “Blower Motor Test”).

F2: Cook Temperature Low

This fault is displayed if the cook cavity temperature drops more than 84°F (47°C) below the set temperature during a cook cycle (registered after five seconds into a cook cycle).

The fault is cleared from the display at the onset of cooking if the cook cavity temperature is within

84°F (47°C) of the set temperature or when the heaters are tested in Test Mode (page 20, section “Top Heater Test” and “Bottom Heater Test”).

F3: Magnetron Current Low

This fault is displayed when the current transformer (CT) on the I/O control board detects less than 10 amps. The fault is monitored when the microwave is on during a cook cycle or in Test Mode.

The fault is cleared from the display at the onset of a cook cycle if the CT detects 10 amps or greater, or when the magnetrons are successfully energized in Test Mode.

F4: Door Monitor Defective

This fault is displayed when the control detects that the monitor interlock switch opens before the primary or secondary interlock switches. Additionally, this fault will blow the 20-amp F3 fuse if the microwave high voltage system is energized when the fault occurs. The fault is cleared from the display when the oven is powered off and then back on.

NOTE: Door interlock switches are in parallel.

For the oven schematic, see page 48 for the Encore and page 62 for the [Encore 2](#). The fault is monitored during a cook cycle and in Test Mode when the microwave is on (page “Test Mode” on page 19).

F5: Magnetron Over Temperature

This fault is displayed if either magnetron thermostat reaches 270°F (138°C), or if either thermostat connector is disconnected.

The thermostats will reset automatically, and are wired in series. The fault is cleared from the display at the onset of a cook cycle if the thermostat is closed and connected properly.

F6: Electrical Compartment Temperature High

This fault is displayed when the temperature of the electrical compartment exceeds 158°F (70°C), as measured by the sensor on the control board. The electrical compartment temperature is monitored once per minute.

The fault is cleared from the display if on the next check, the thermocouple temperature is below 158°F (70°C).

F7: RTD Open

This fault is displayed when the control detects that one or both of the RTDs is “open.” The display will show “999” indicating the RTD is open or disconnected. The fault is cleared when the control detects continuity.

F8: Heat Low

This fault displays when the oven is warming up or during Test Mode (page 19) if the cook cavity temperature fails to rise at least 14°F (7°C) within a given 30 seconds.

F9: Cook Cavity Temperature High

This fault will signal that the catalyst has “flashed” due to excessive grease. The fault occurs when the RTD senses +650°F (343°C) for more than 40 seconds but less than 2 minutes. The fault will only appear in the fault log and will not terminate a cook cycle upon discovery.

Fault Code and Description	When Active				Refer to...
	Warmup	Idle	Cooking	Test Mode	
F1: Blower Running Status Bad	✓	✓	✓	✓	Page 37
F2: Cook Temperature Low			✓		Page 38
F3: Magnetron Current Low			✓	✓	Page 39
F4: Door Monitor Defective			✓	✓	Page 40
F5: Magnetron Over Temperature			✓	✓	Page 40
F6: EC Temperature High	✓	✓	✓	✓	Page 41
F7: RTD Open	✓	✓	✓	✓	Page 41
F8: Heat Low	✓			✓	Page 42
F9: Cook Cavity Temperature High			✓	✓	Page 42

Fault codes are listed in order of hierarchy. For example, if during cooking the oven experiences an F1 and F2 fault, the oven will report only the F1 fault because the software will halt all actions upon discovering the F1 fault.

FAULT CODES F1 - F5 AND F7 WILL TERMINATE A COOK CYCLE UPON DISCOVERY.

Fault Code Troubleshooting

From Test Mode, you can run oven diagnostics and check fault counts. To access Test Mode see page 19, or turn on Diagnostic mode see page “Diagnostic Mode” on page 20, section “Demo Mode ON/OFF.” To locate oven components for testing, adjustment, or replacement, see the Appendix.

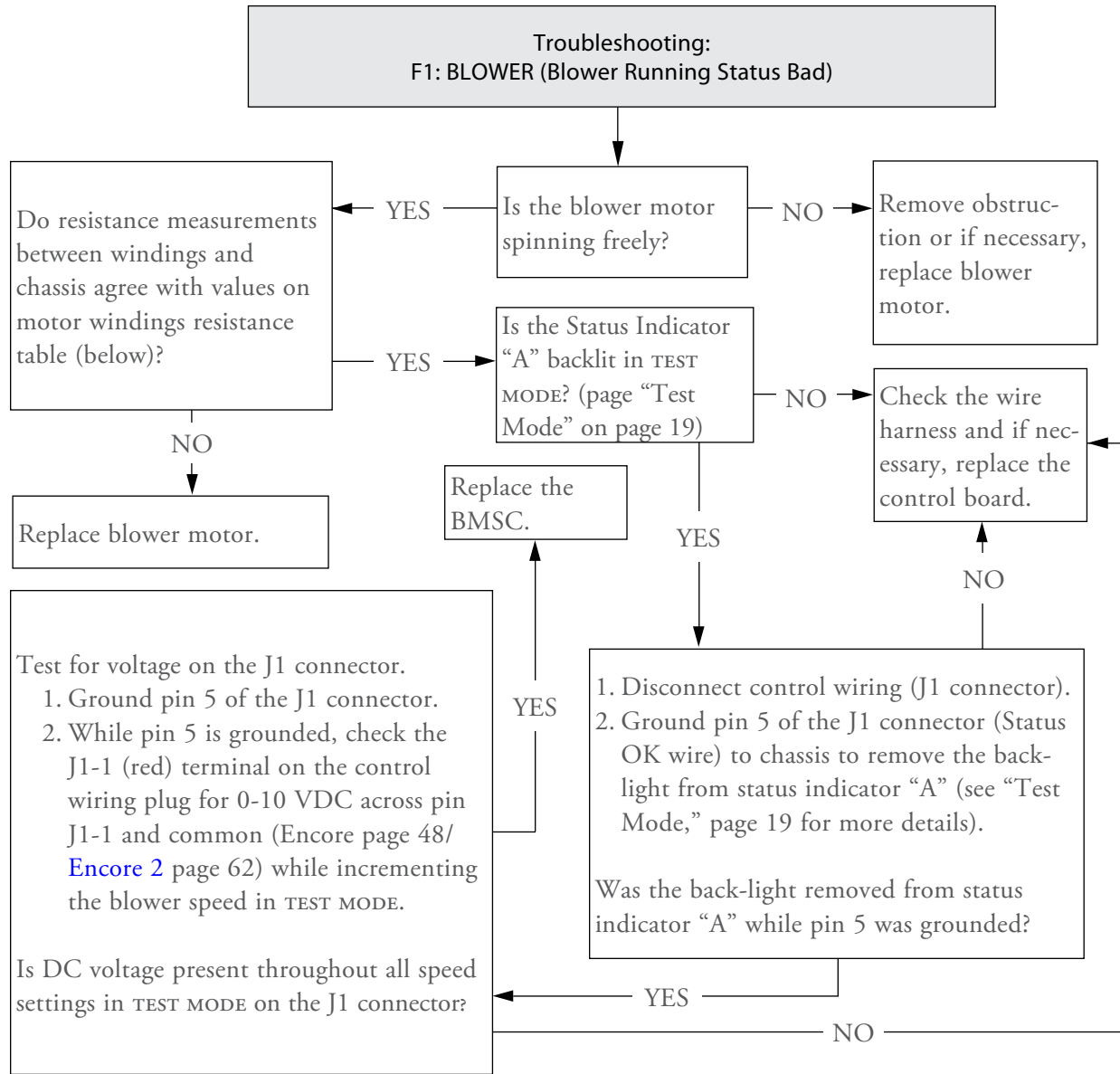

To	From	Description	Expected Resistance
Black	Red	Winding (A-B)	2.0-2.6 Ω
Black	White	Winding (A-C)	2.0-2.6 Ω
Red	White	Winding (B-C)	2.0-2.6 Ω
Black, Red, or White	Green	Windings to Chassis	Open

Motor Windings Resistance Table

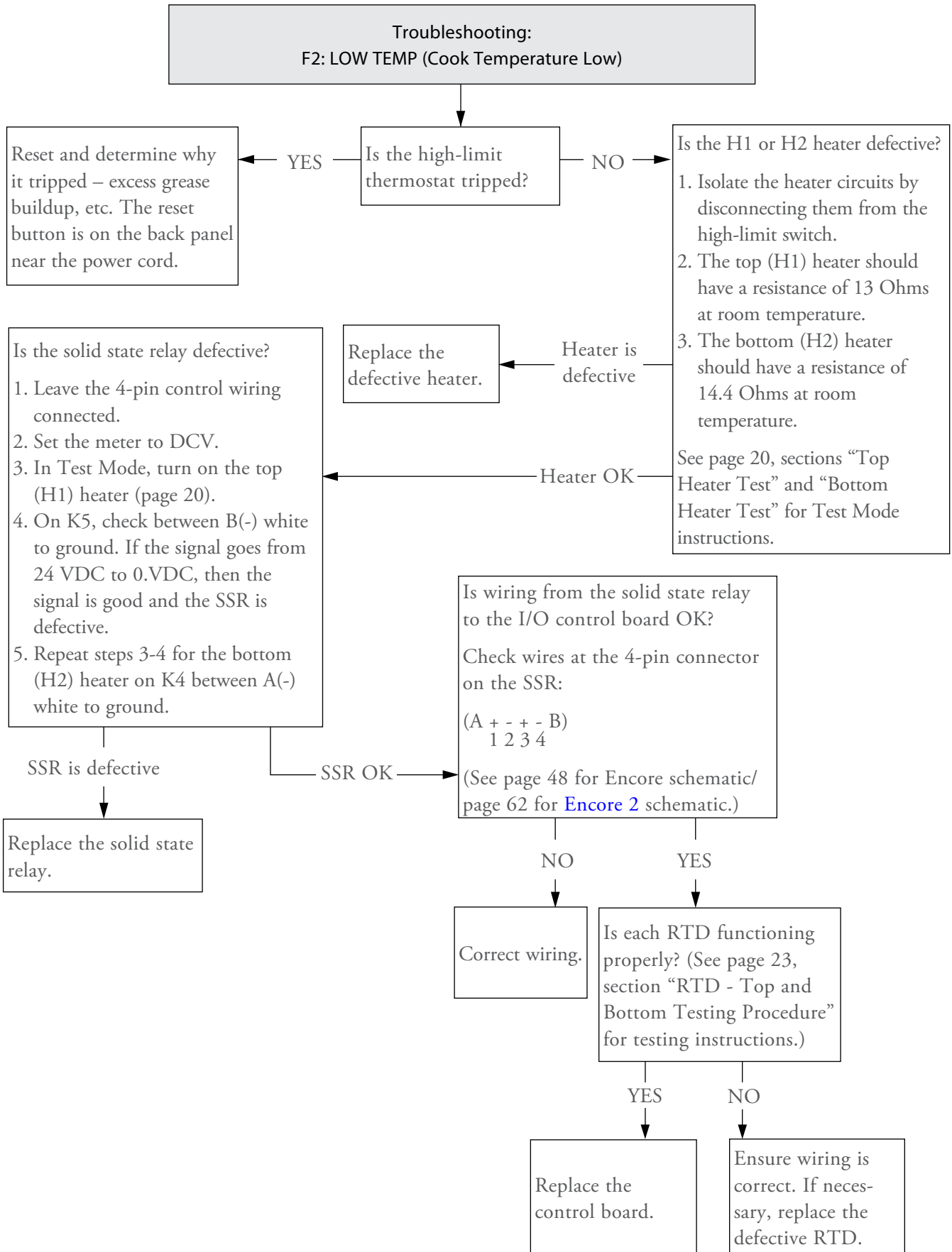

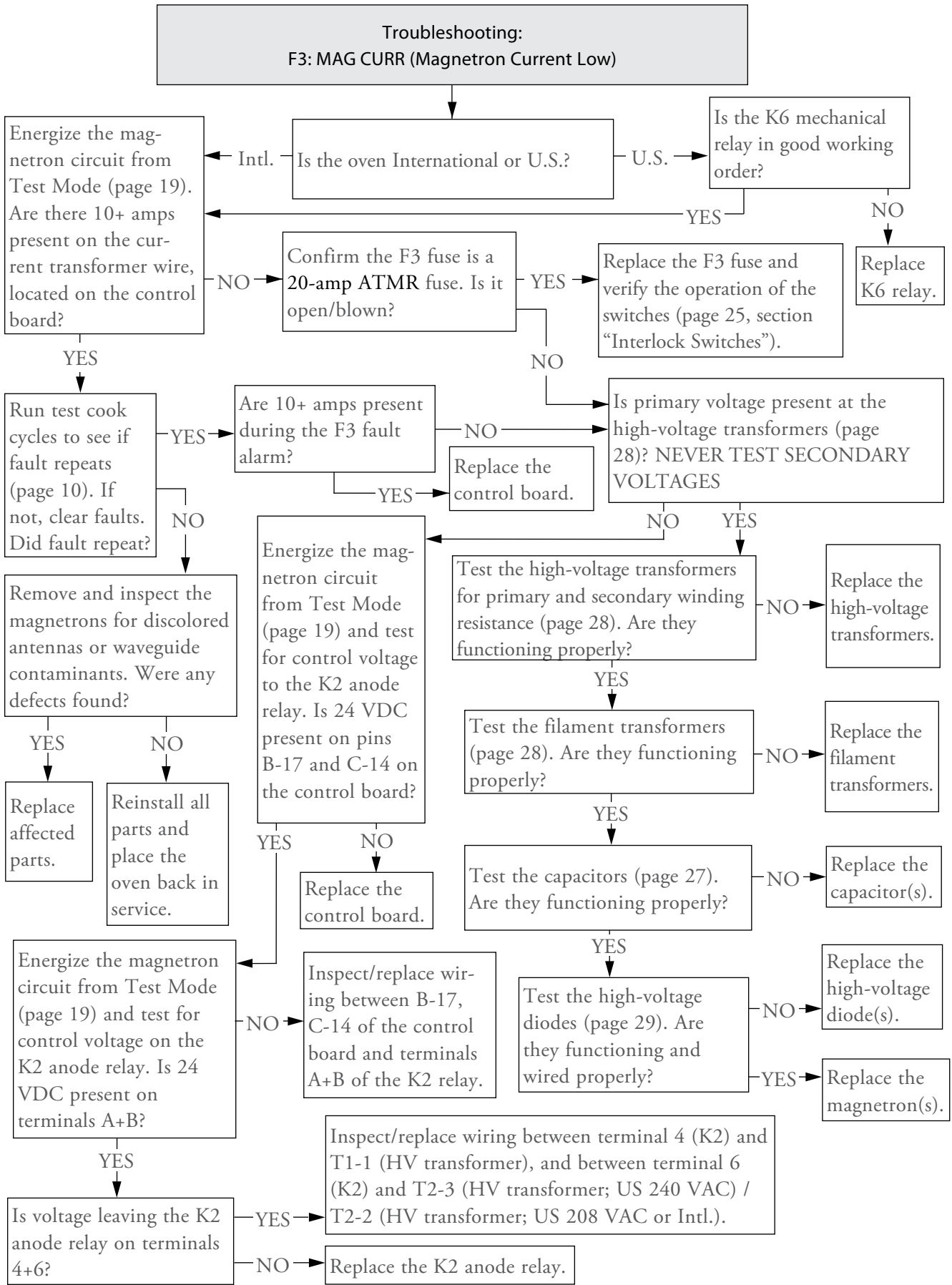

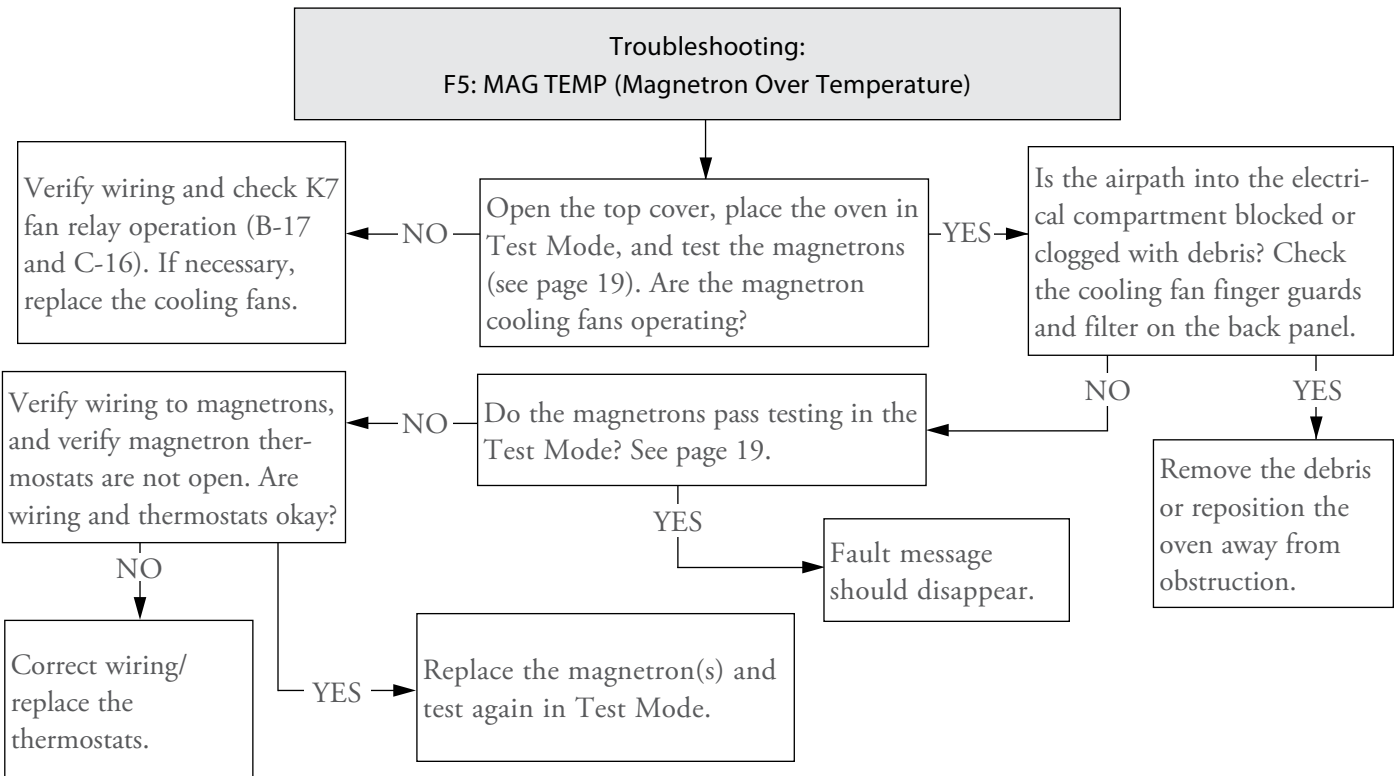
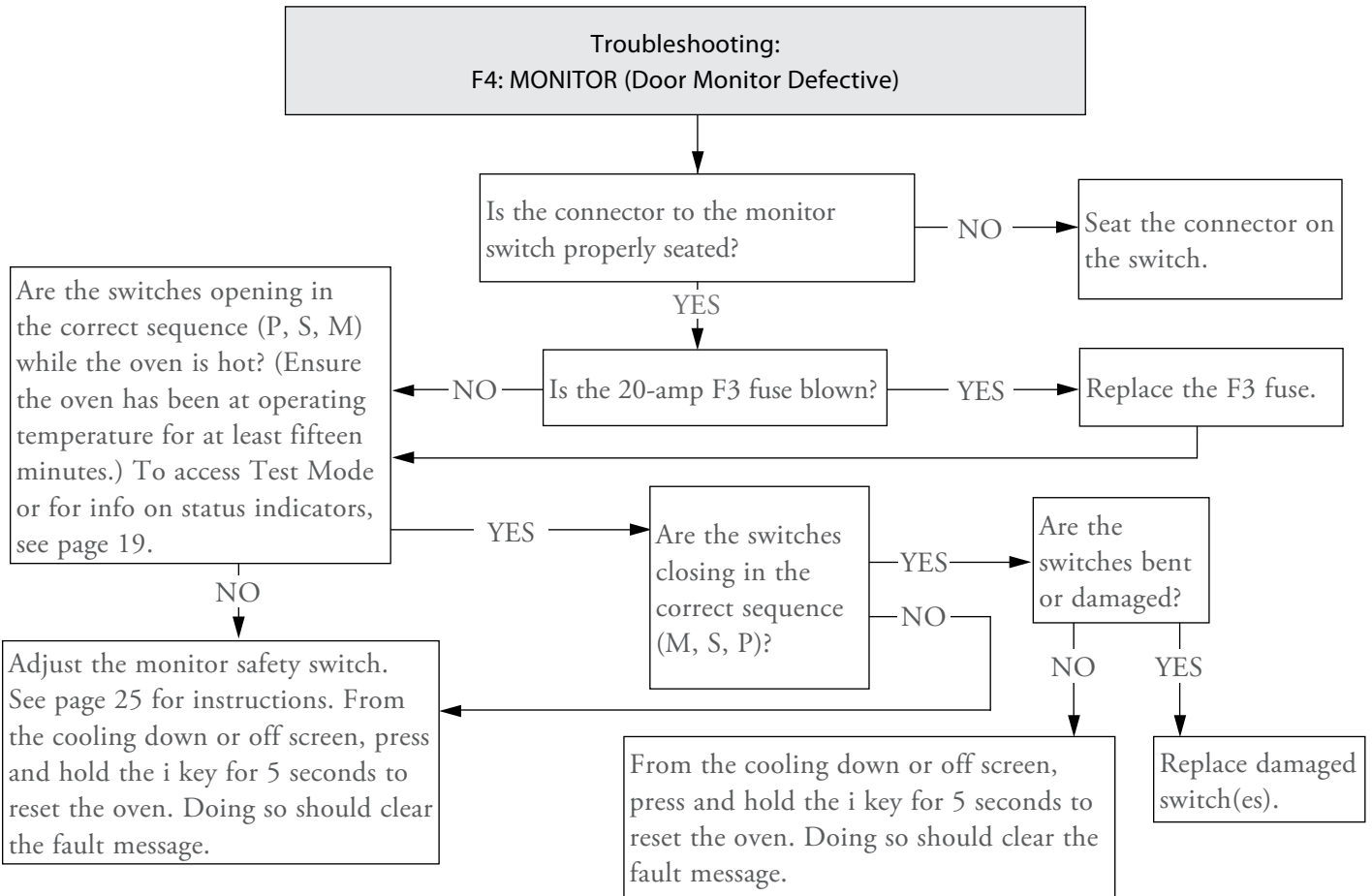

**Troubleshooting:
F6: EC TEMP (Electrical Compartment Temperature High)**

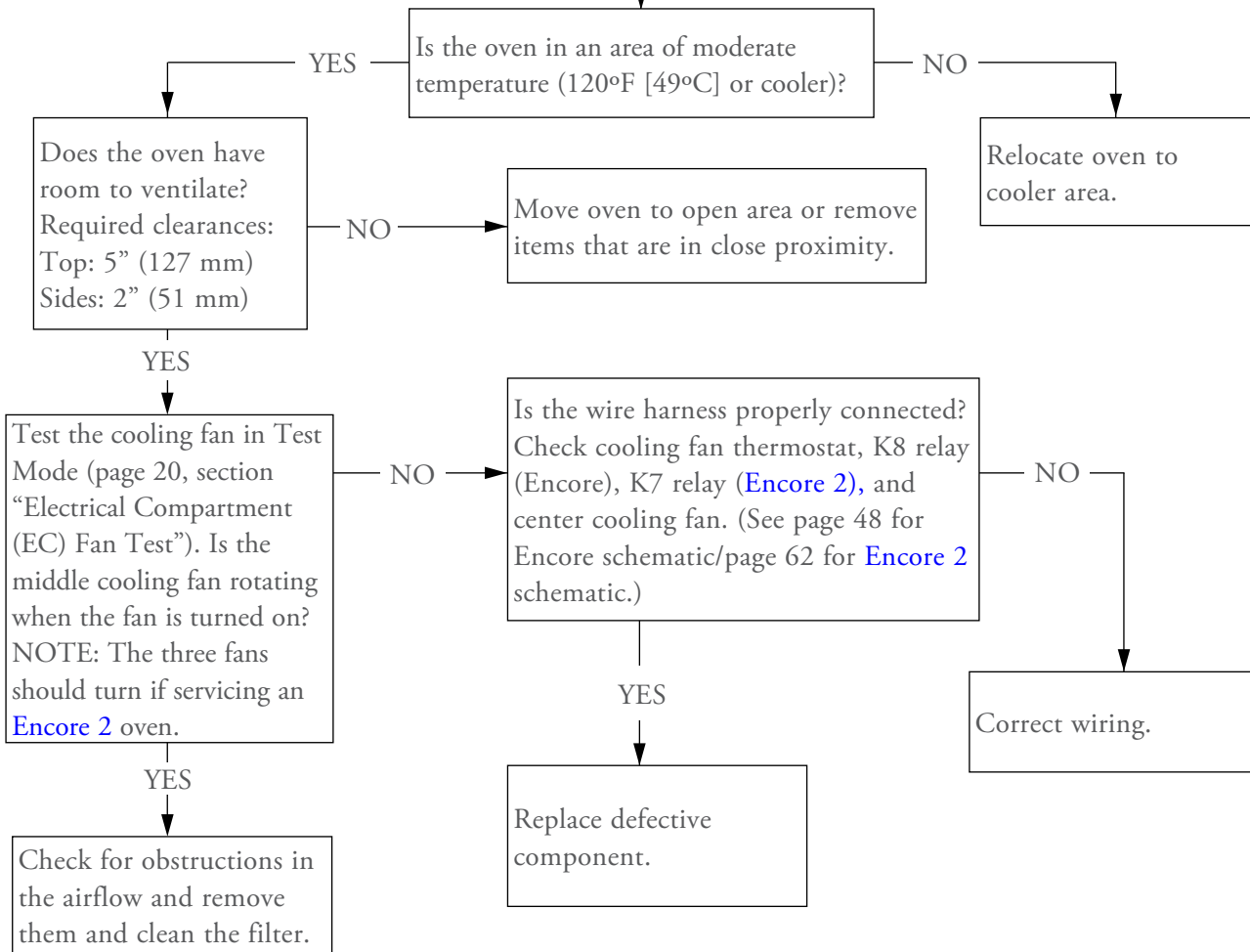

**Troubleshooting:
F7: THERMO (RTD Open)**

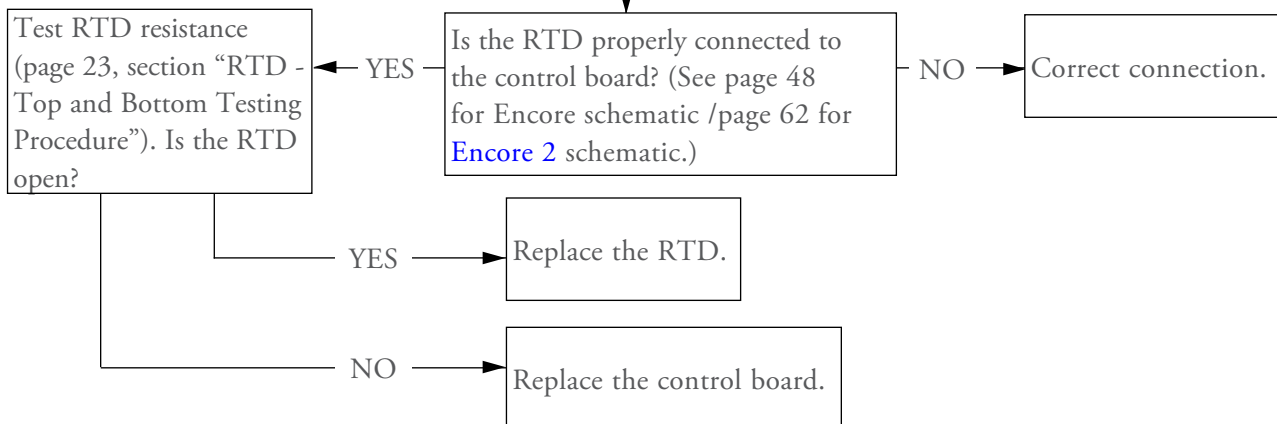

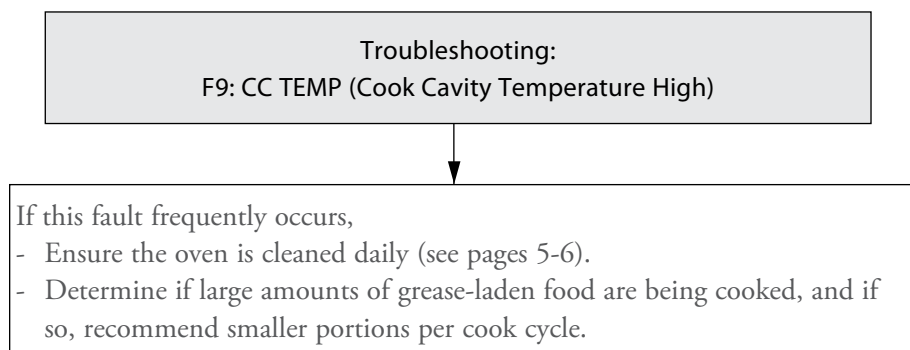
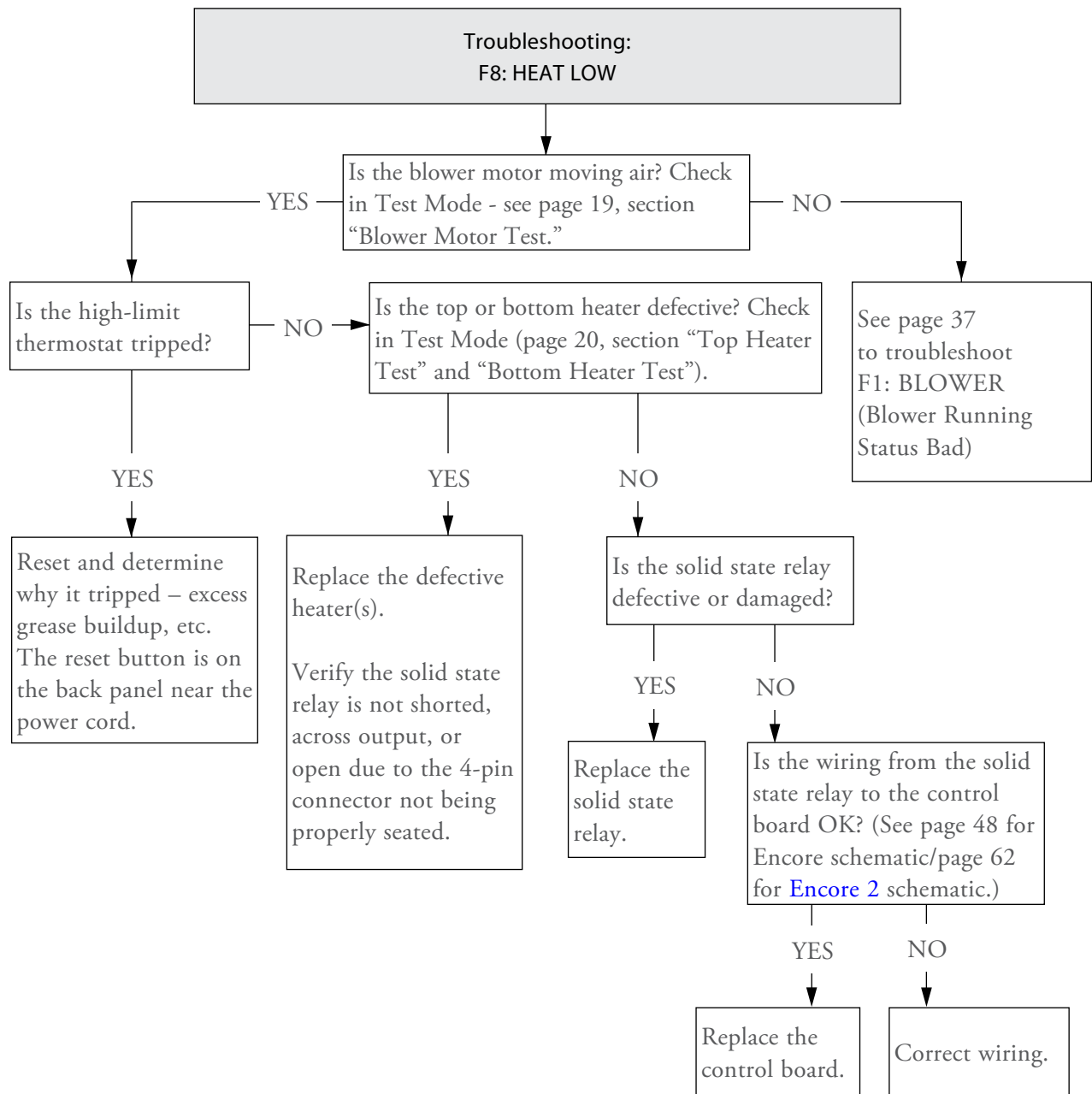

Non-Fault Code Troubleshooting

This section provides troubleshooting tips for issues that may occur independently of an oven fault.

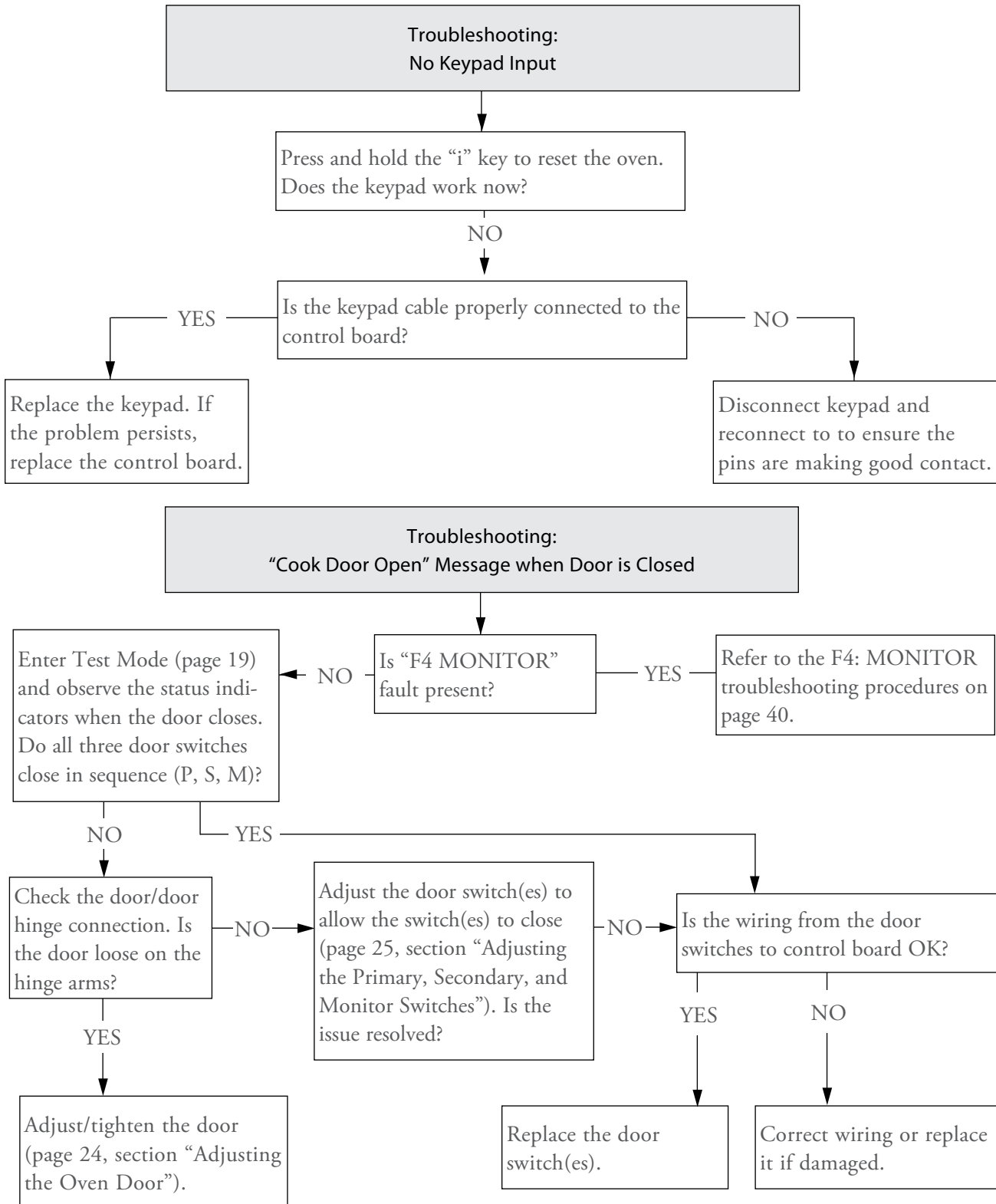

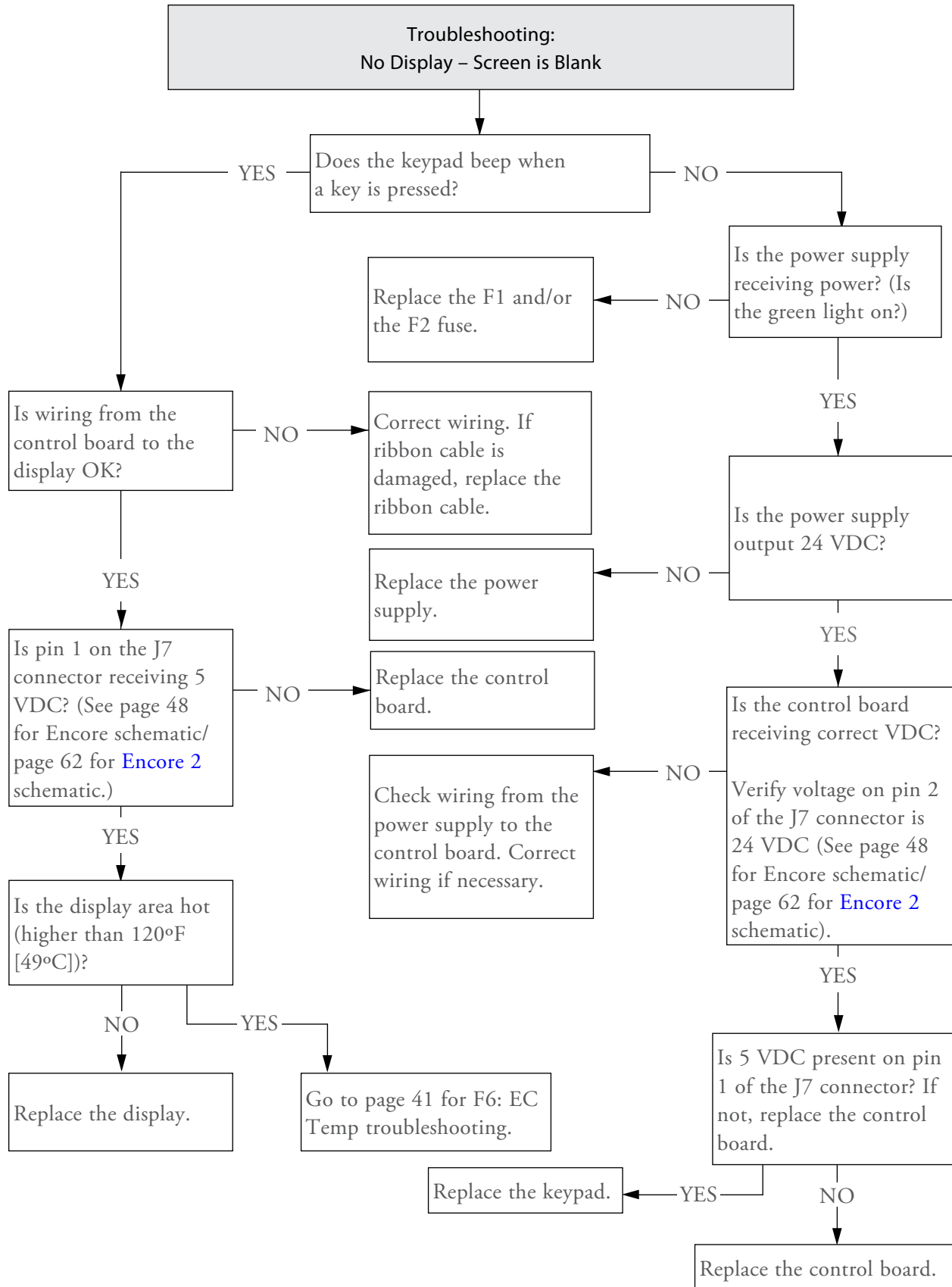

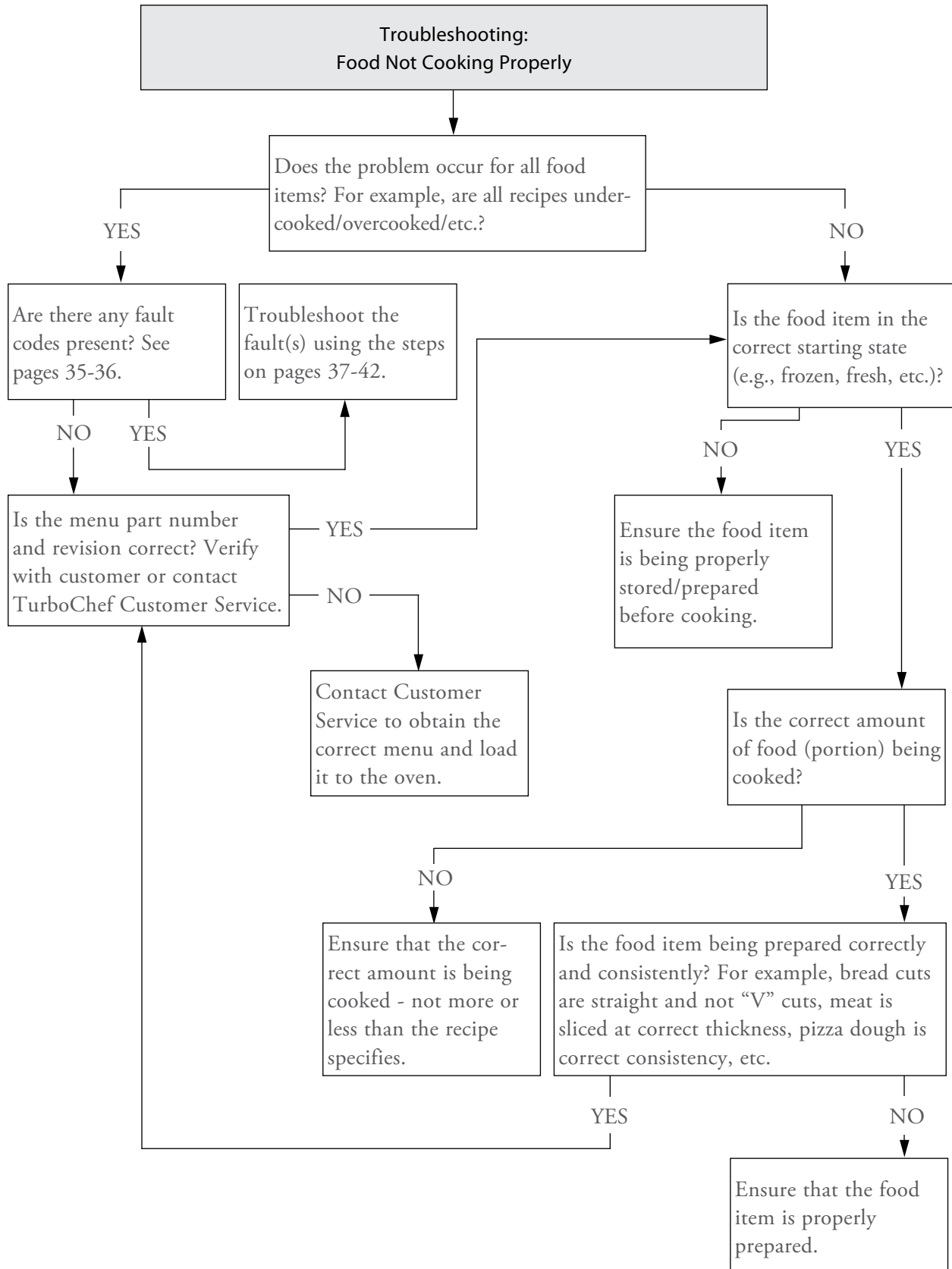

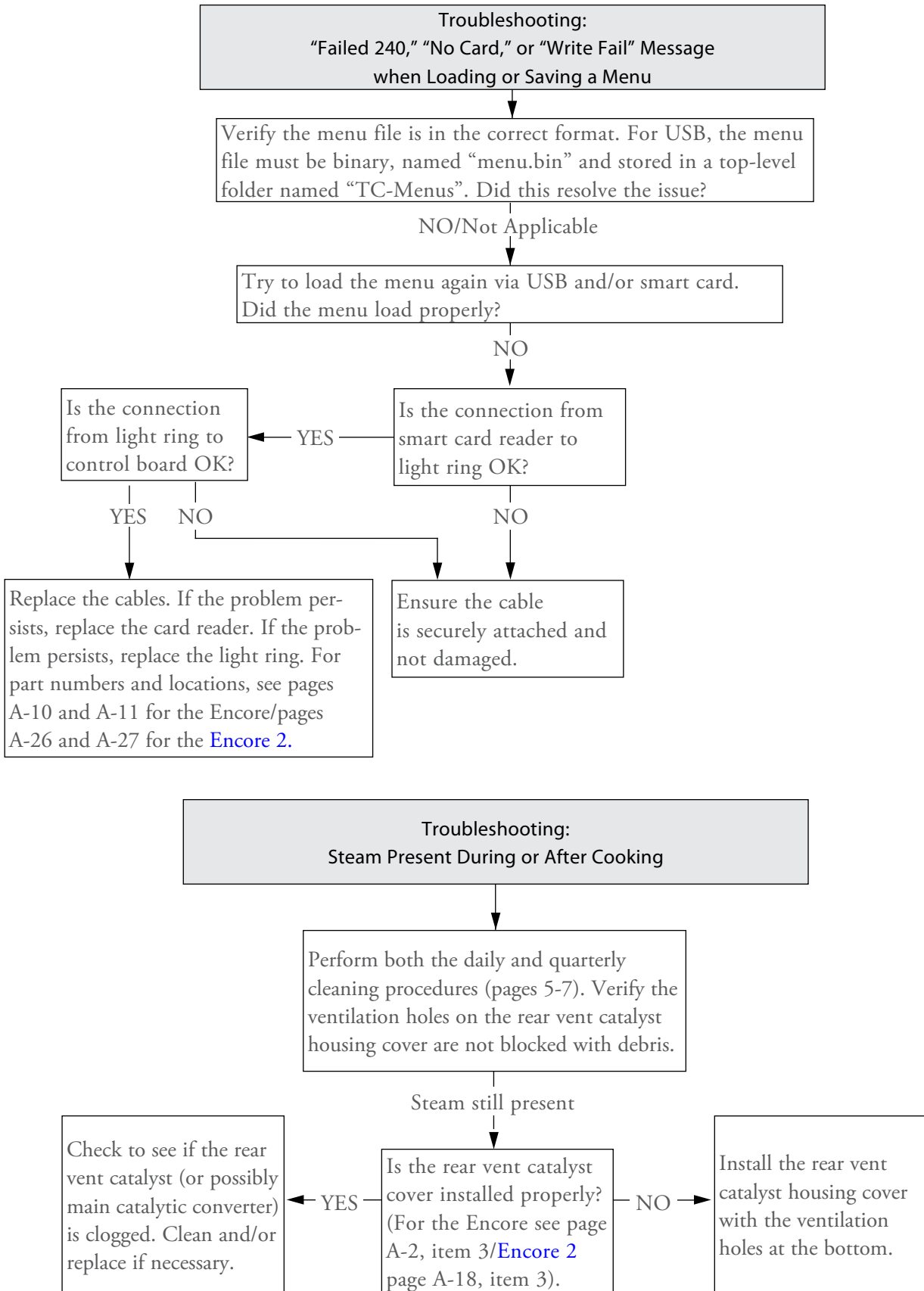

Encore Oven Schematic and Wire Harnesses

(see page 61 for [Encore 2](#))

Encore Oven Schematic and Wire Harnesses

This section provides an overall wiring schematic for the Encore oven. It also provides detailed drawings of each wire harness with labeled connectors.

The following drawings are provided:

- Relay Schematic (below)
- Oven Schematic (page 48)
- High Voltage Microwave Circuit 1 and 2 (page 50)
- Low Voltage (page 52)
- Heater (page 52)
- Cooling Fans (page 54)
- Line Voltage (pages 56-59)

Relay Schematic

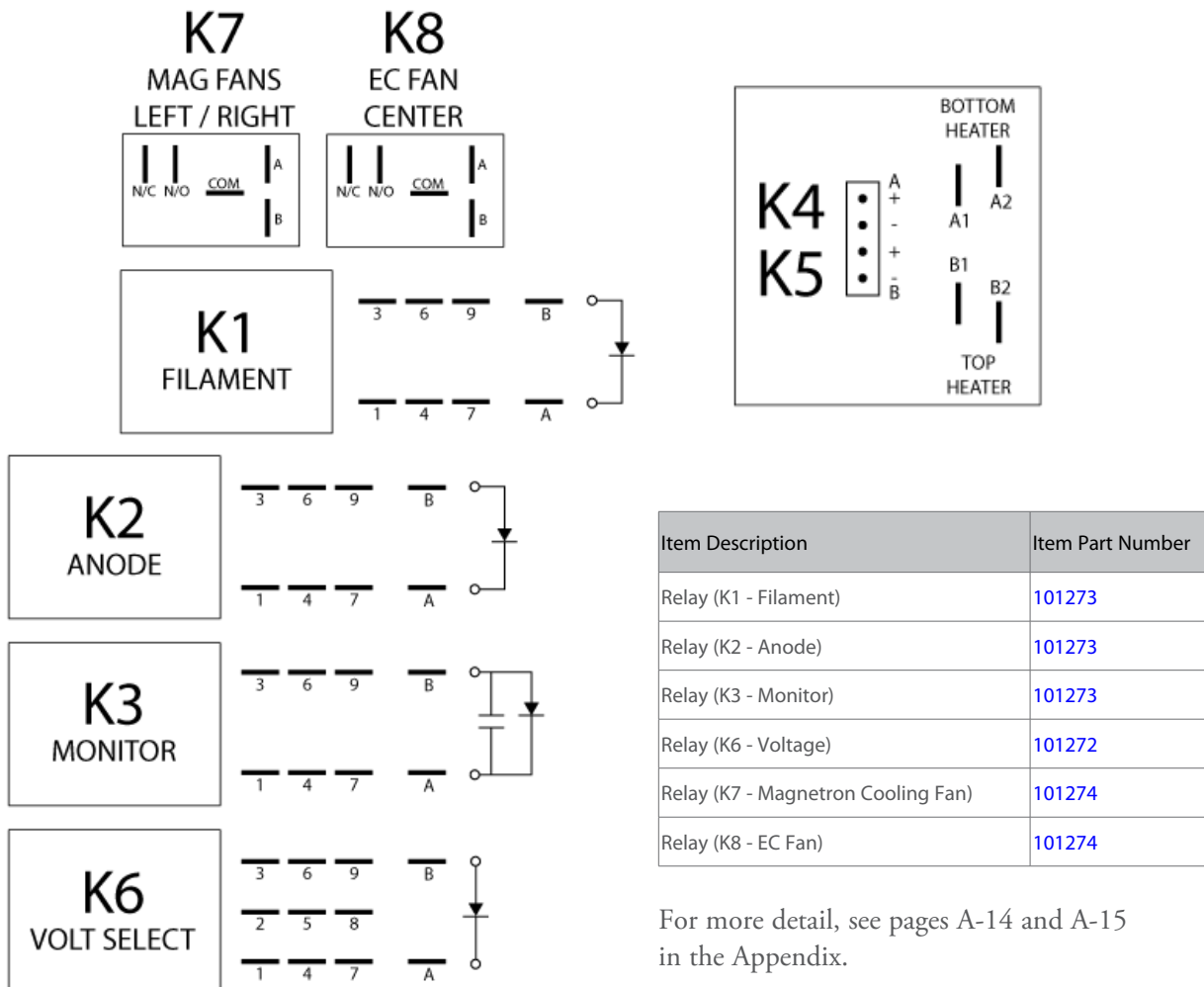

For more detail, see pages A-14 and A-15 in the Appendix.

COLOR CODE (LINE VOLTAGE)
 BL - BLUE = LINE V (208/240)
 BR - BROWN = LINE V (208/240)
 OR = 240 LINE INPUT FOR TAP 3 ON TRANSFORMERS
 BK = HI-TEMP 240 VAC WIRE

COLOR CODE (HIGH VOLTAGE/TENSION)
 WH - HI-VOLTAGE WIRE FOR MAG 1
 BK - HI-VOLTAGE WIRE FOR MAG 2

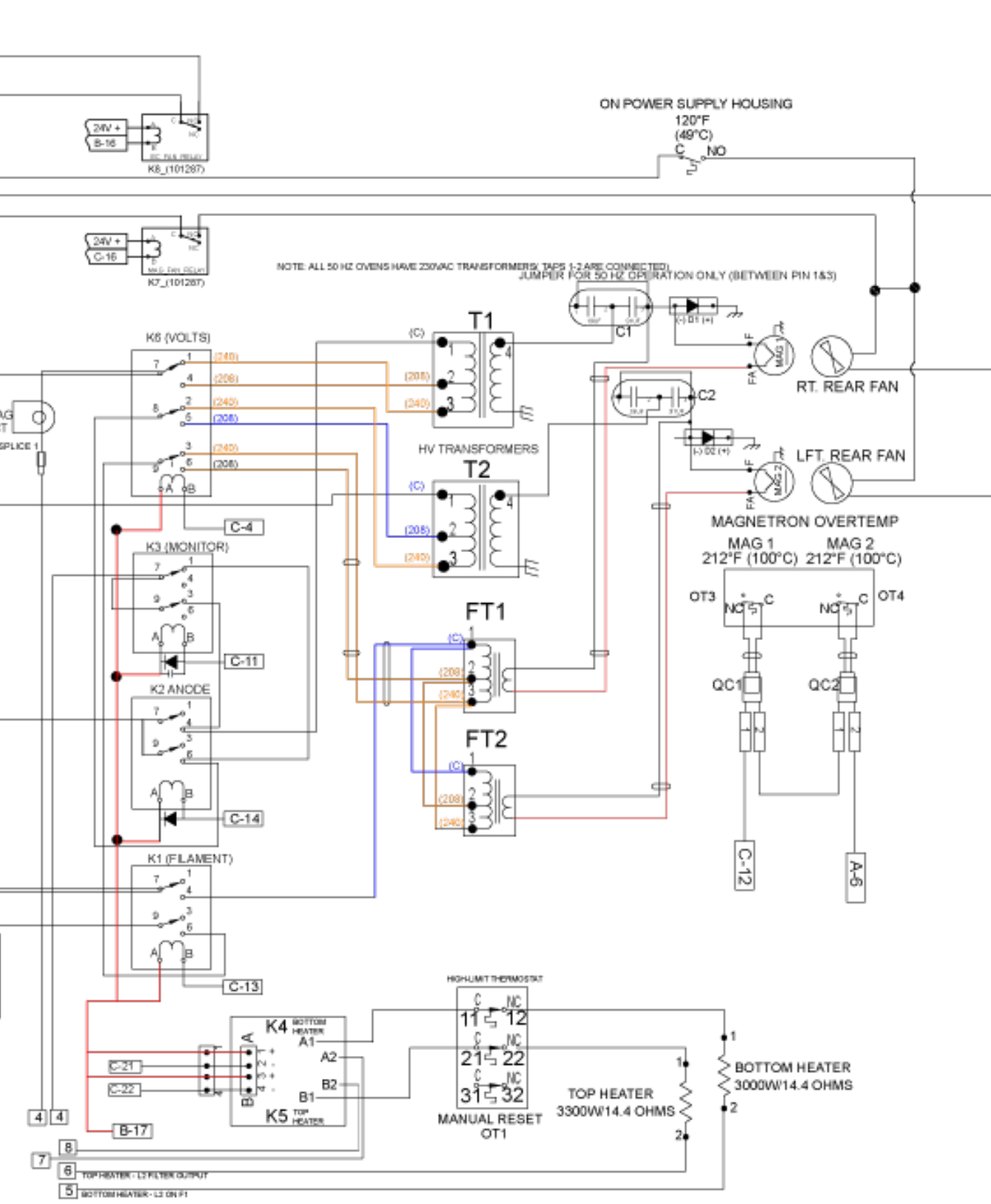
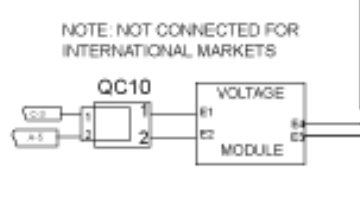
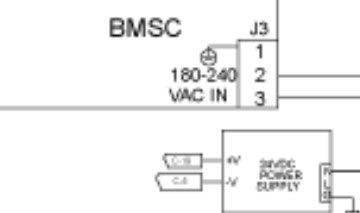
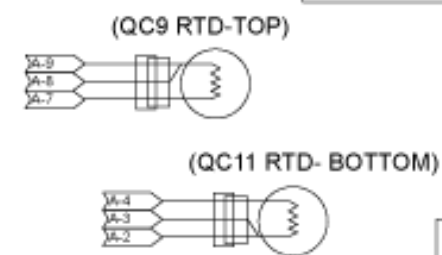
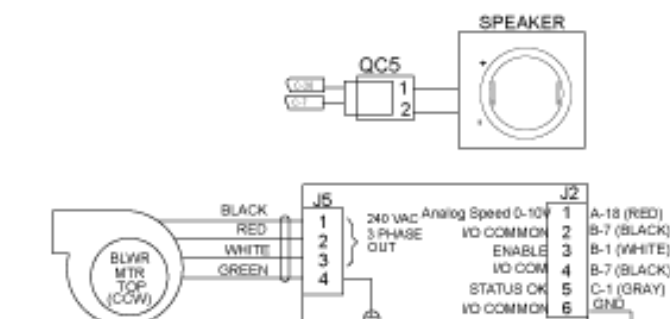
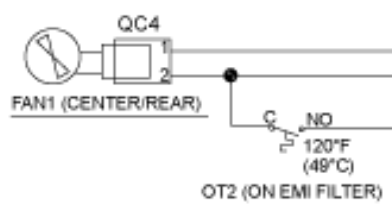
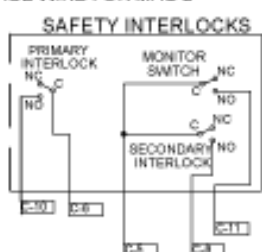
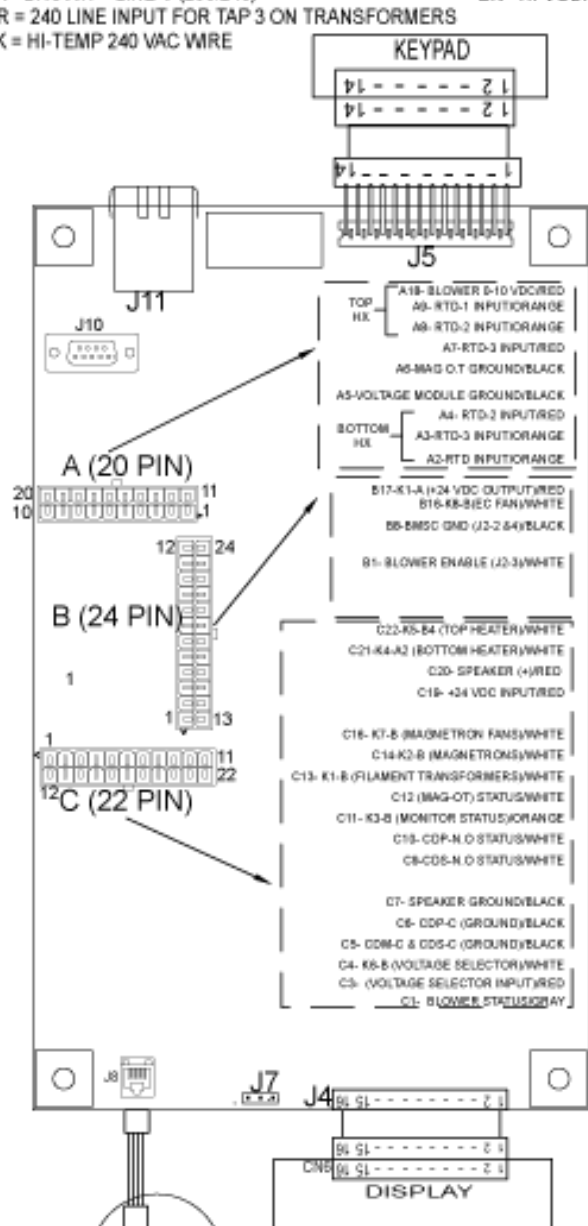

COLOR CODE (LOW/CONTROL VOLTAGE)
 BK - BLACK = 24 VDC COMMON
 OR - ORANGE = STATUS INPUT
 WH - WHITE = CONTROL OUTPUT
 RD - RED = +24VDC

ENC-1208-1: Harness, Wiring, HV, MW Circuit 1

⚠ DANGER: Before removing any oven part, be sure the oven has completed “cooling down” (see “Step 9” on page 11) and is removed from the power source.

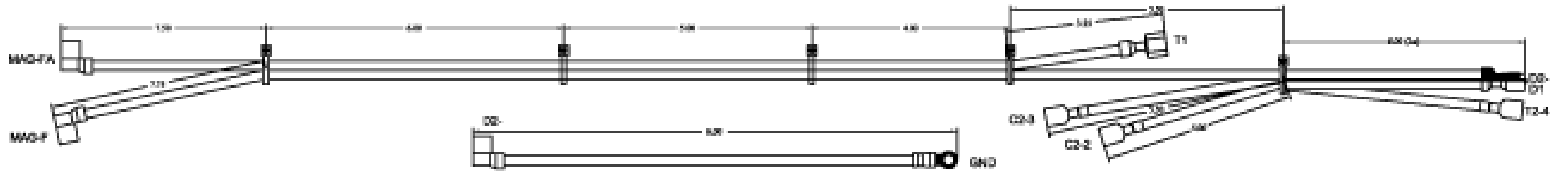

ENC-1208-2: Harness, Wiring, HV, MW Circuit 2

⚠ DANGER: Before removing any oven part, be sure the oven has completed “cooling down” (see “Step 9” on page 11) and is removed from the power source.

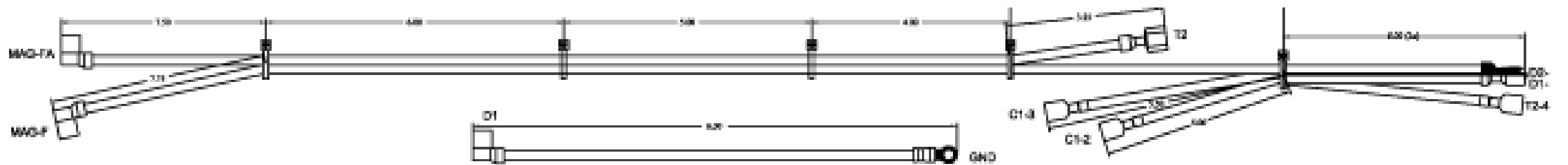

ENC-1210: Harness, Wiring, Low Voltage

⚠ DANGER: Before removing any oven part, be sure the oven has completed “cooling down” (see “Step 9” on page 11) and is removed from the power source.

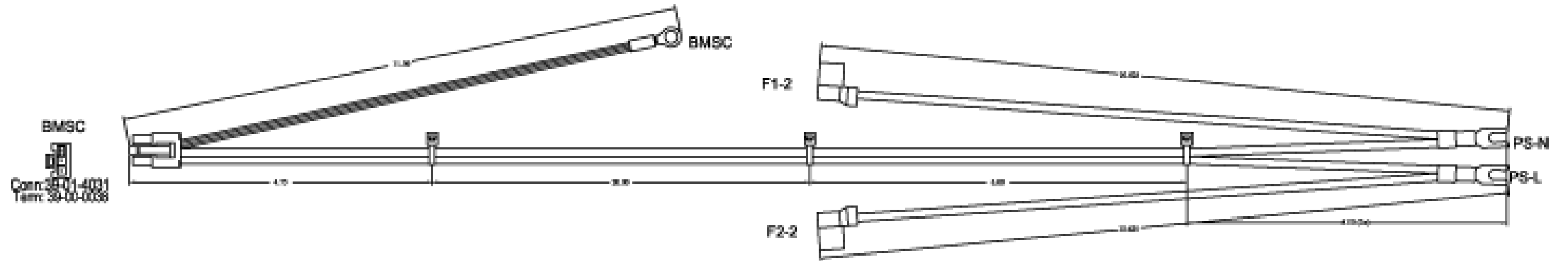

ENC-1212: Harness, Wiring, Heater

⚠ DANGER: Before removing any oven part, be sure the oven has completed “cooling down” (see “Step 9” on page 11) and is removed from the power source.

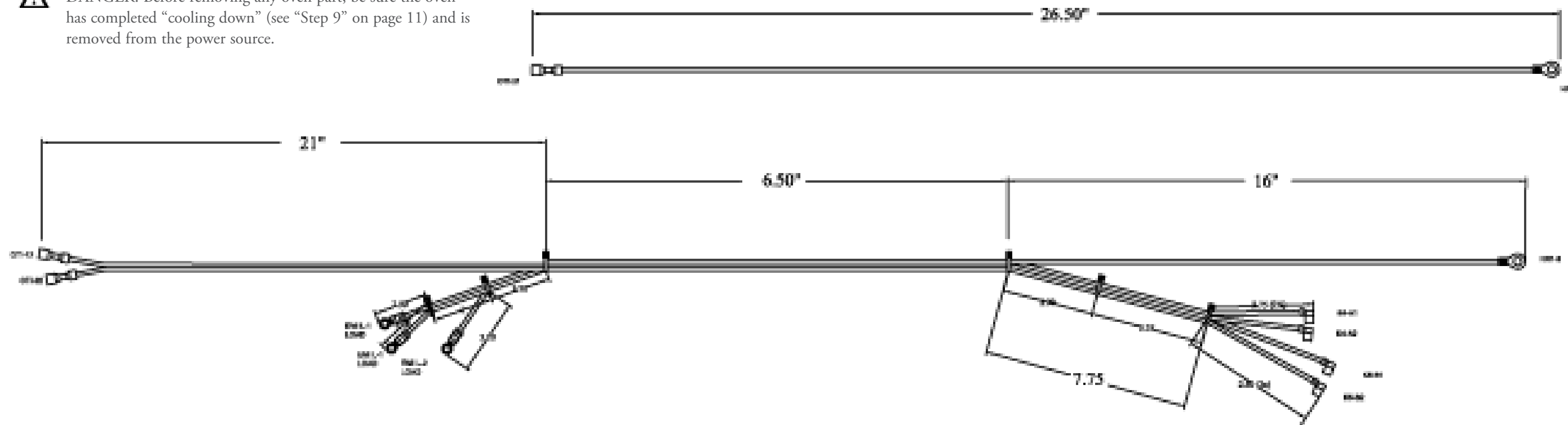

ENC-1213: Harness, Wiring, Cooling Fans

⚠ DANGER: Before removing any oven part, be sure the oven has completed “cooling down” (see “Step 9” on page 11) and is removed from the power source.

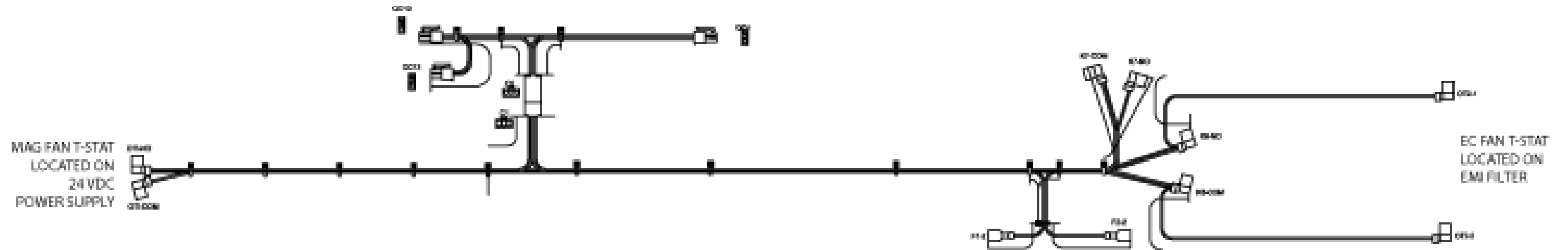

ENC-1214 View 1: Harness, Wiring, Line Voltage

⚠ DANGER: Before removing any oven part, be sure the oven has completed “cooling down” (see “Step 9” on page 11) and is removed from the power source.

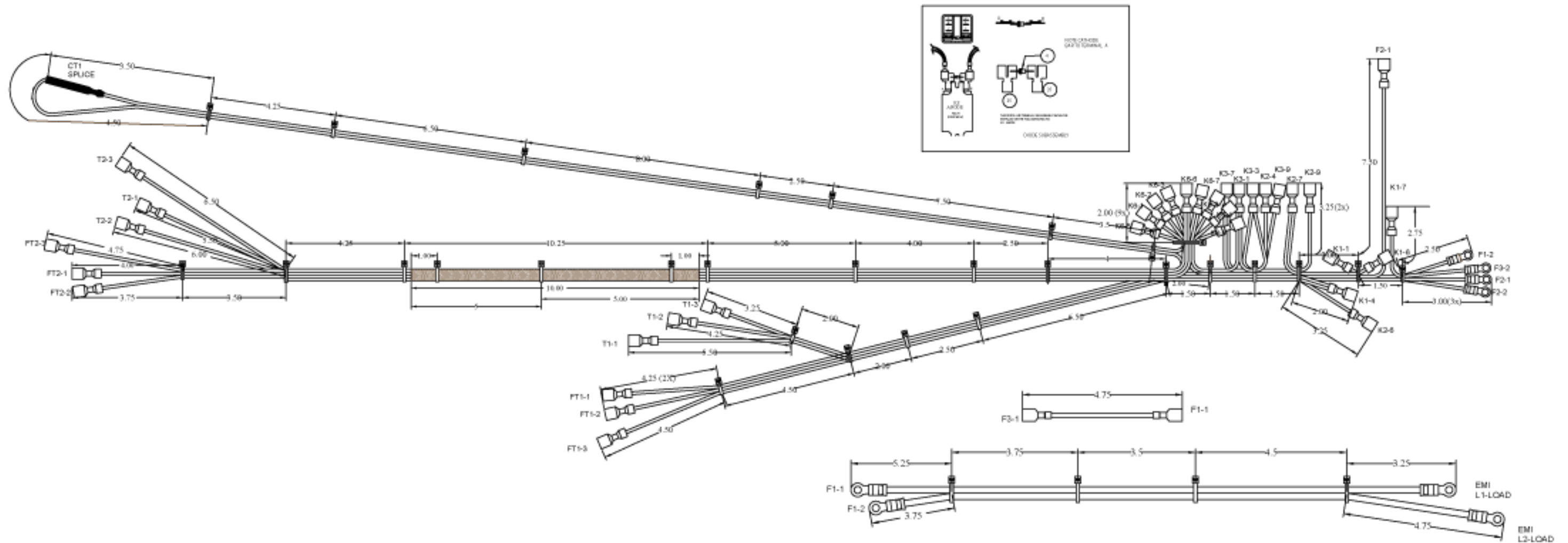

Continued on next page...

ENC-1214 View 2: Harness, Wiring, Line Voltage

⚠ DANGER: Before removing any oven part, be sure the oven has completed “cooling down” (see “Step 9” on page 11) and is removed from the power source.

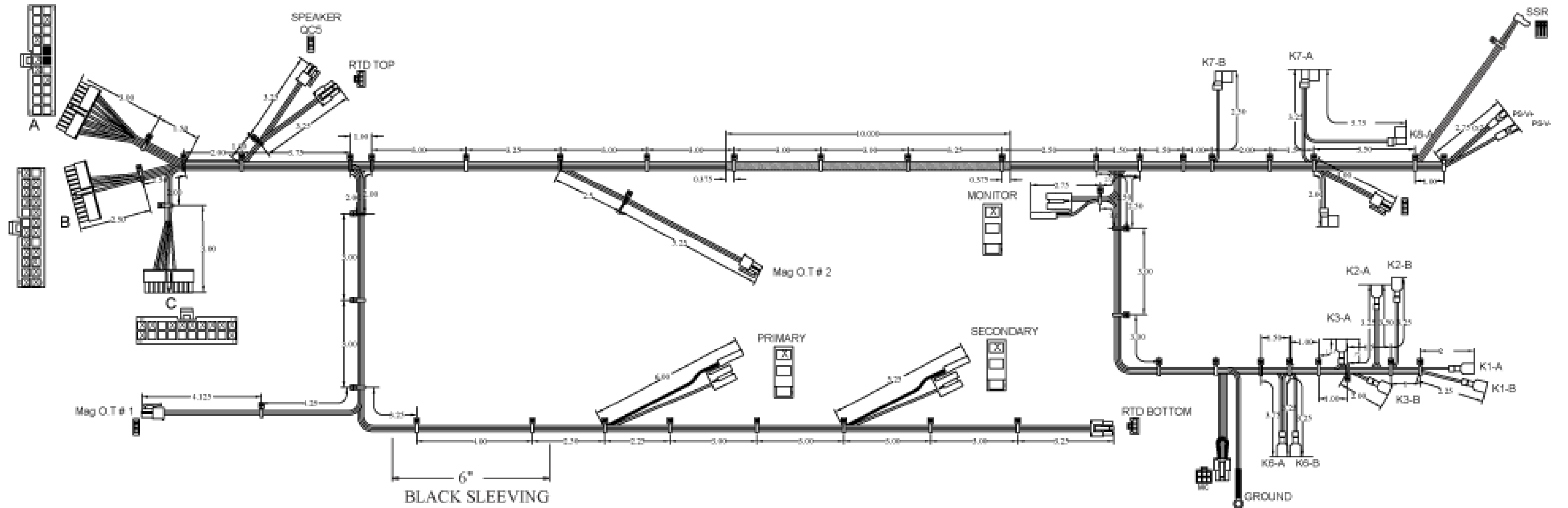
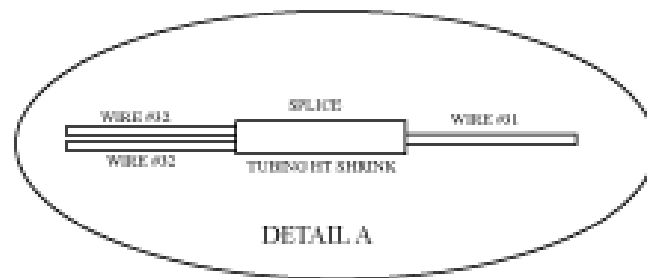

*This page intentionally
left blank.*

Encore 2 Oven Schematic and Wire Harnesses

(see page 47 for Encore)

Encore 2 Oven Schematic and Wire Harnesses

This section provides an overall wiring schematic for the Encore oven. It also provides detailed drawings of each wire harness with labeled connectors.

The following drawings are provided:

- Relay Schematic (below)
- Oven Schematic (page 62)
- Heater (page 64)
- High Voltage Microwave Circuit 1 and 2 (page 66)
- Low Voltage (page 66)
- Line Voltage (pages 68-71)
- Cooling Fans (page 72)

Relay Schematic

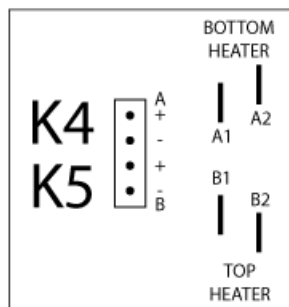
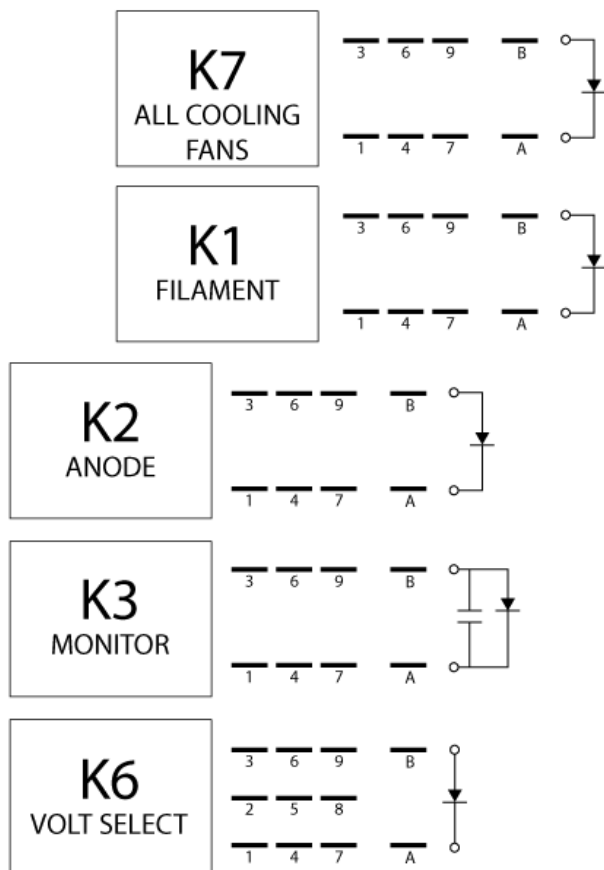

Item Description	Item Part Number
Relay (K1 - Filament)	101273
Relay (K2 - Anode)	101273
Relay (K3 - Monitor)	101273
Relay (K6 - Voltage)	101272
Relay (K7 - All Cooling Fans)	101273

For more detail, see pages A-30 and A-31 in the Appendix.

COLOR CODE (LINE VOLTAGE)
 BL - BLUE = LINE V (208/240)
 BR - BROWN = LINE V (208/240)
 OR = 240 LINE INPUT FOR TAP 3 ON TRANSFORMERS
 BK = HI-TEMP 240 VAC WIRE

COLOR CODE (HIGH VOLTAGE/TENSION)
 WH - HI-VOLTAGE WIRE FOR MAG 1
 BK - HI-VOLTAGE WIRE FOR MAG 2

TURBOCHEF TECHNICAL SUPPORT
 800.908.8726 (USA)
 +214.379.6000 (INTERNATIONAL)

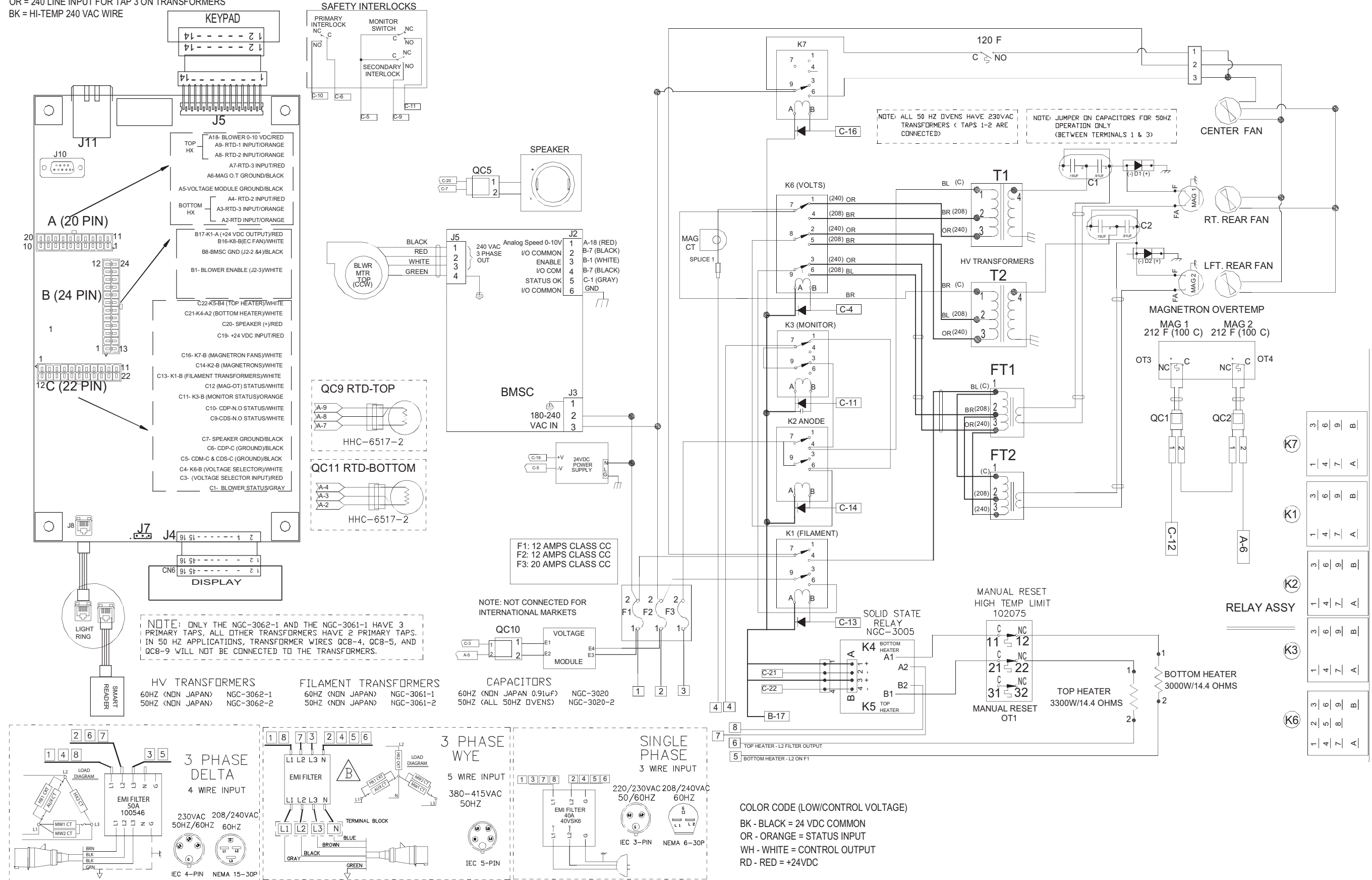

ENC-1401: Harness, Wiring, Heater

⚠ DANGER: Before removing any oven part, be sure the oven as completed “cooling down” (see “Step 9” on page 11) and is removed from the power source.

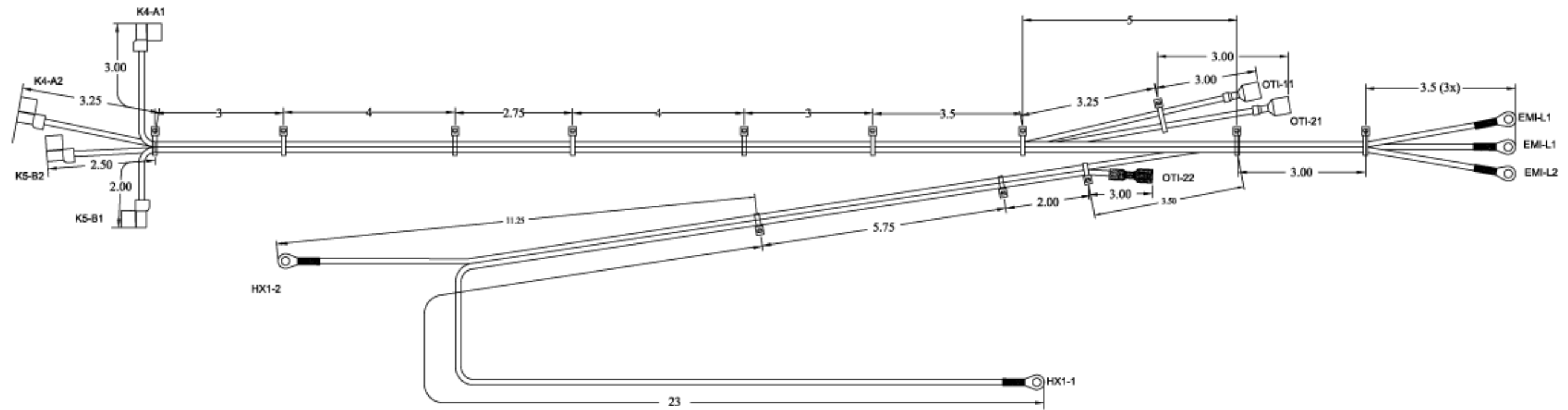

ENC-1402: Harness, Wiring, HV, MW Circuits 1 and 2

⚠ DANGER: Before removing any oven part, be sure the oven has completed “cooling down” (see “Step 9” on page 11) and is removed from the power source.

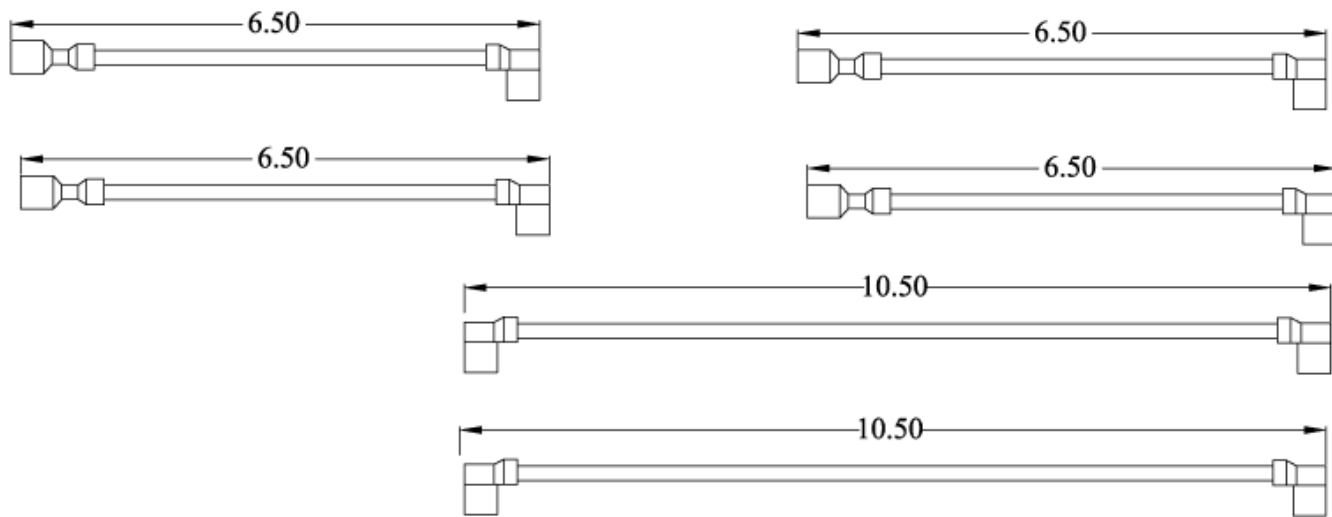

ENC-1403: Harness, Wiring, Low Voltage

⚠ DANGER: Before removing any oven part, be sure the oven has completed “cooling down” (see “Step 9” on page 11) and is removed from the power source.

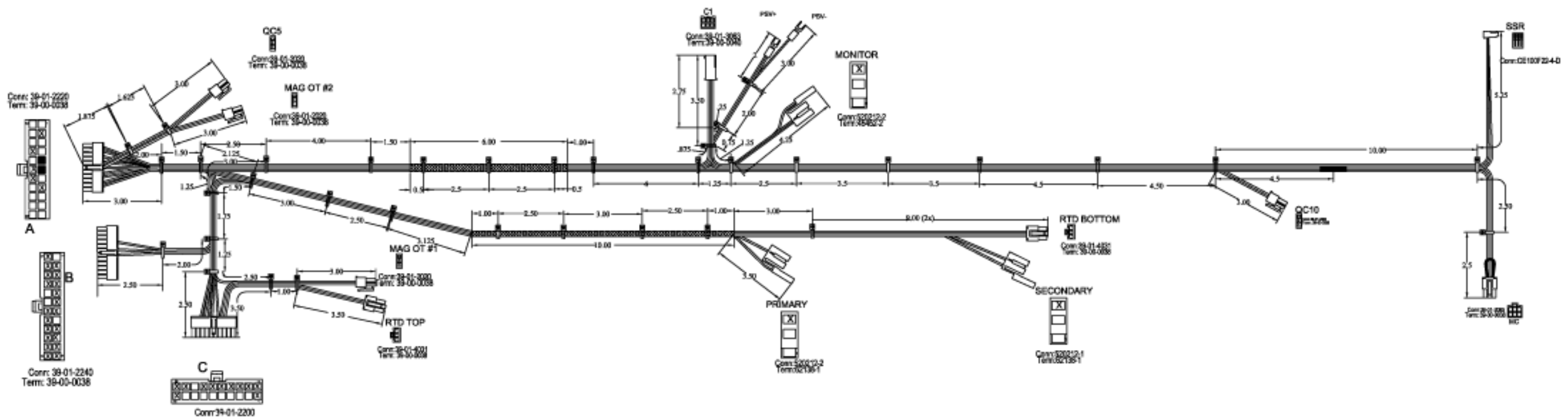

ENC-1404 View 1: Harness, Wiring, Line Voltage

⚠ DANGER: Before removing any oven part, be sure the oven has completed “cooling down” (see “Step 9” on page 11) and is removed from the power source.

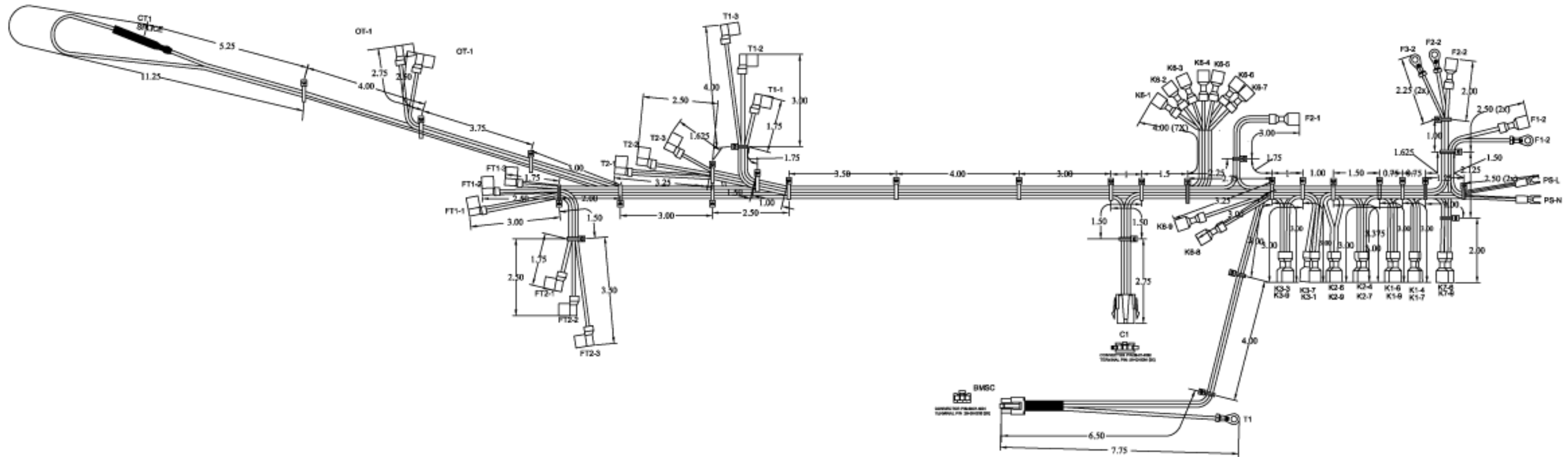

Continued on next page...

ENC-1404 View 2: Harness, Wiring, Line Voltage

⚠ DANGER: Before removing any oven part, be sure the oven has completed “cooling down” (see “Step 9” on page 11) and is removed from the power source.

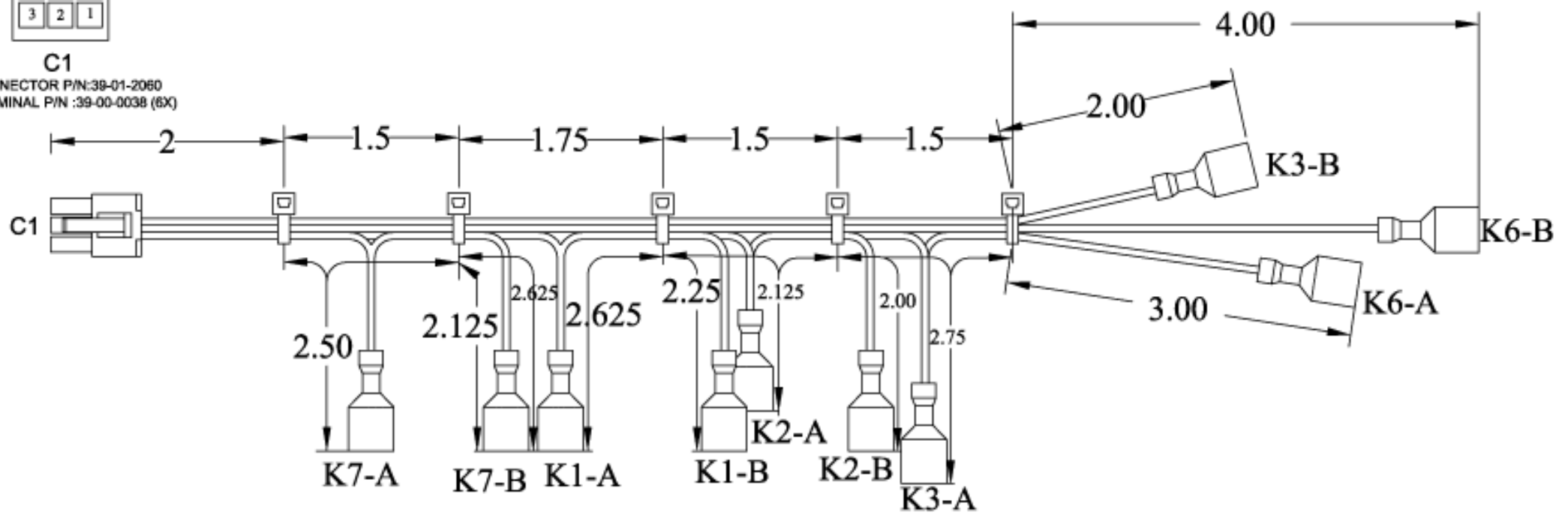
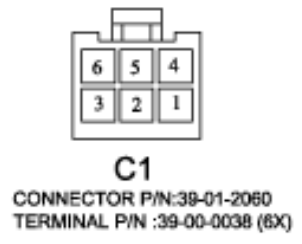
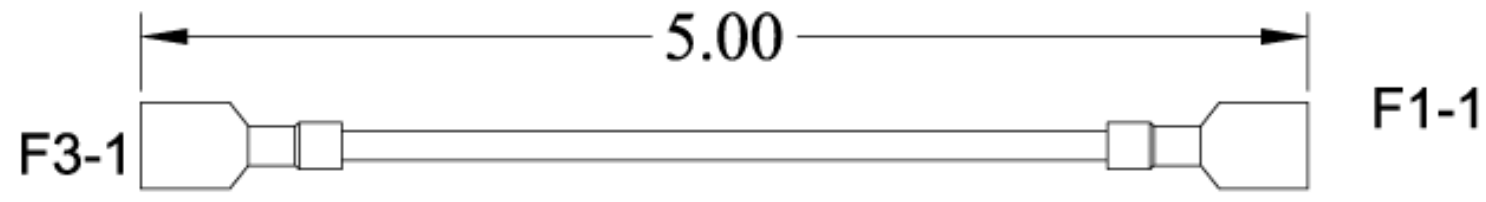
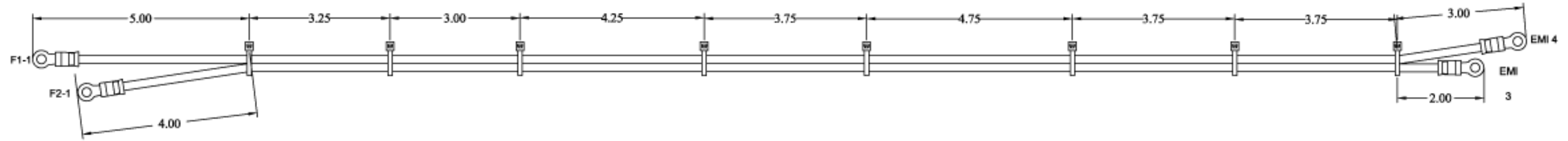

ENC-1405: Harness, Wiring, Cooling Fans

 DANGER: Before removing any oven part, be sure the oven has completed “cooling down” (see “Step 9” on page 11) and is removed from the power source.

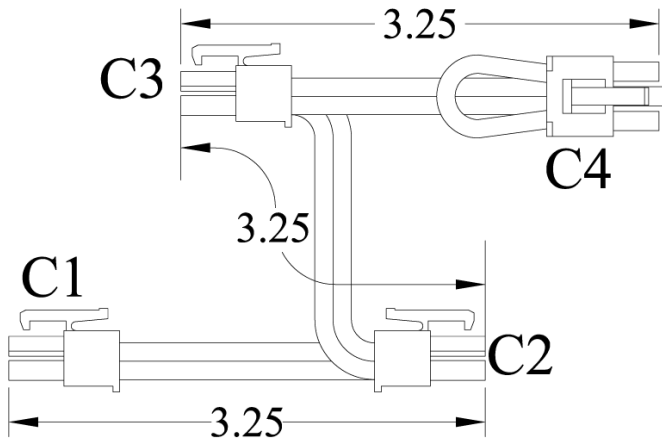

Encore Appendix: Replacing Oven Components

(see page A-61 for [Encore 2](#))

Replacing Oven Components

This appendix provides illustrations for removing serviceable items, as well as the item numbers and descriptions for those items. It also includes the item numbers and descriptions for the fasteners used to secure each component to the oven chassis.

The appendix is divided into the following sections:

- Oven Exterior (pages A-2 through A-3)
- Impingement System (pages A-4 through A-5)
- Microwave System (pages A-6 through A-7)
- Oven Door and Related Parts (A-8 through A-9)
- Control System (A-10 through A-11)
- Power Components (A-12 through A-15)

If you have any questions that are not addressed in this manual or appendix, please contact TurboChef Customer Service at 800.90TURBO or +1 214.379.6000.

Oven Exterior

⚠ DANGER: Before removing any oven part, be sure the oven has completed “cooling down” (see “Step 9” on page 11) and is removed from the power source.

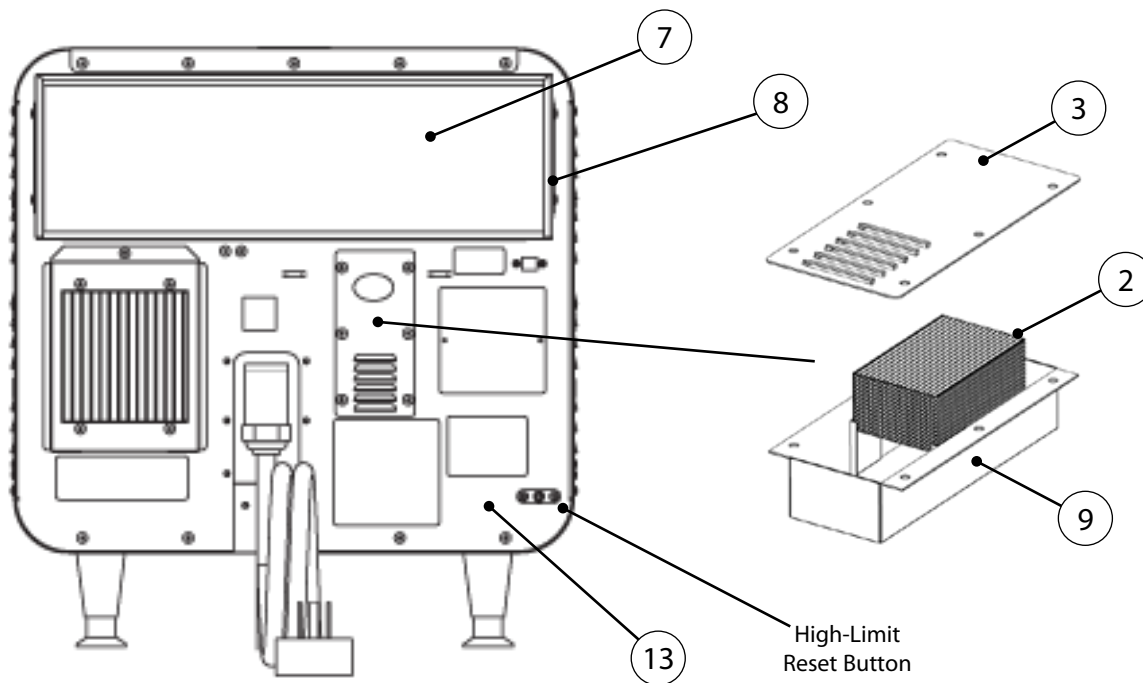
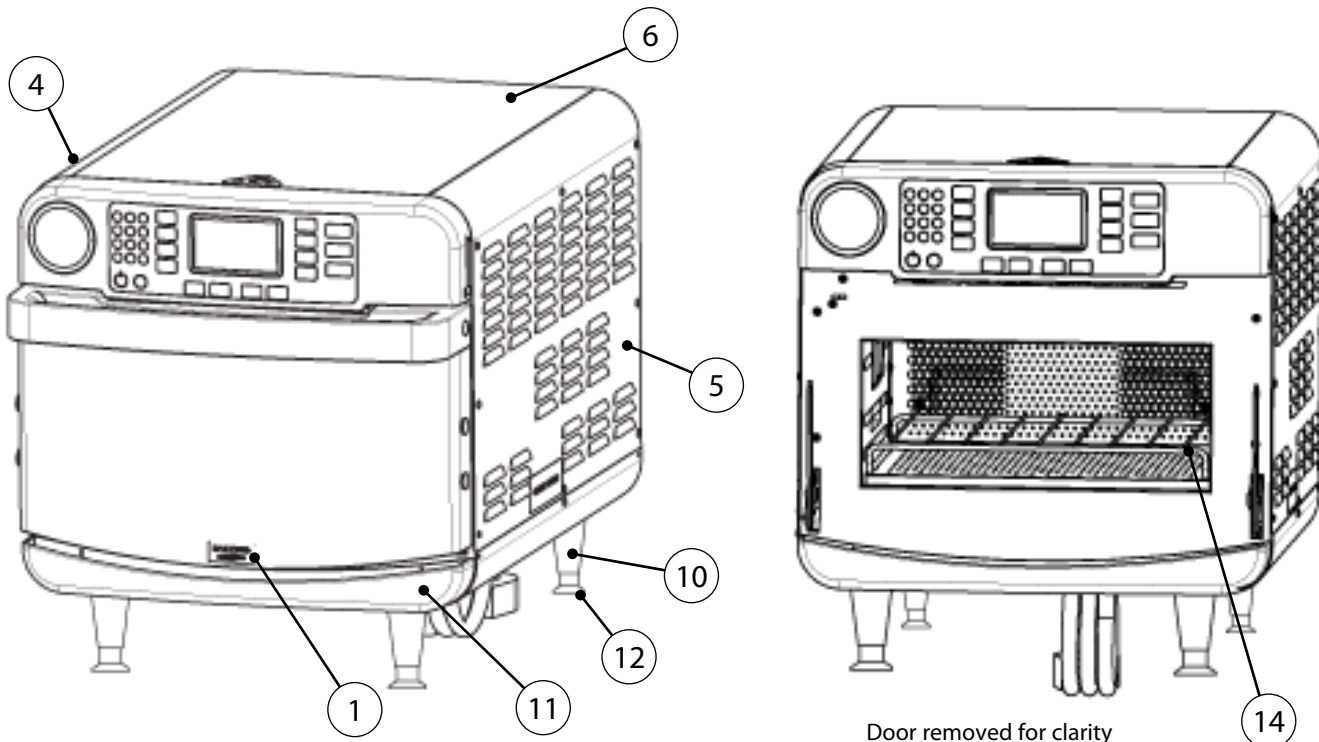



Figure Reference #	Item Description	Item Part Number	Fastener Description	Fastener Part Number(s)
1	Badge, Logo, Encore/ Encore 2	ENC-1192	Nut, Push, 1/8"	101293 (qty 2)
2	Catalytic Converter, Vent Tube	RWD-9191	None	None
3	Cover, Exhaust Tube	ENC-1080	Screw, #8 x 3/8, Ph Mod Truss Hd, Cres	101682 (qty 6)
4	Cover, Left Side, Black	ENC-1109-9005	Screw, #8 x 3/8, Serr Ph Truss Hd, Bk Zinc Screw, #8 x 1/2, Security, Torx Hd, Bk Oxide	101369 (qty 7) 102756 (qty 1)
5	Cover, Right Side, Black	ENC-1108-9005	Screw, #8 x 3/8, Serr Ph Truss Hd, Bk Zinc Screw, #8 x 1/2, Security, Torx Hd, Bk Oxide	101369 (qty 7) 102756 (qty 1)
6	Cover, Top, Black	ENC-1133-9005	Screw, #8 x 3/8, Ph Mod Truss Hd, Cres Screw, #8 x 1/2, Serr Ph Truss Hd, Sheet Mtl	101682 (qty 5) 101688 (qty 4)
7	Filter, Air	ENC-1114	None	None
8	Filter Bracket	ENC-1113	Screw, #8 x 3/8, Ph Mod Truss Hd, Cres	101682 (qty 4)
9	Housing, Exhaust Tube	ENC-1079	Screw, #8 x 3/8, Ph Mod Truss Hd, Cres	101682 (qty 6)
10	Leg, Plastic, Black (x4)	HHB-3205	None	None
11	Lower Front Panel	ENC-1103-T001	None	None
12	Pad, Abrasive, Non-Slip (x4)	NGC-1187	None	None
13	Panel, Rear	ENC-1105	Screw, #8 x 3/8, Ph Mod Truss Hd, Cres	101682 (qty 7)
14	Rack, Oven	ENC-1216	None	None

Impingement System

 **DANGER:** Before removing any oven part, be sure the oven has completed “cooling down” (see “Step 9” on page 11) and is removed from the power source.

NOTE: For clarity, some components have been removed from the illustrations below.

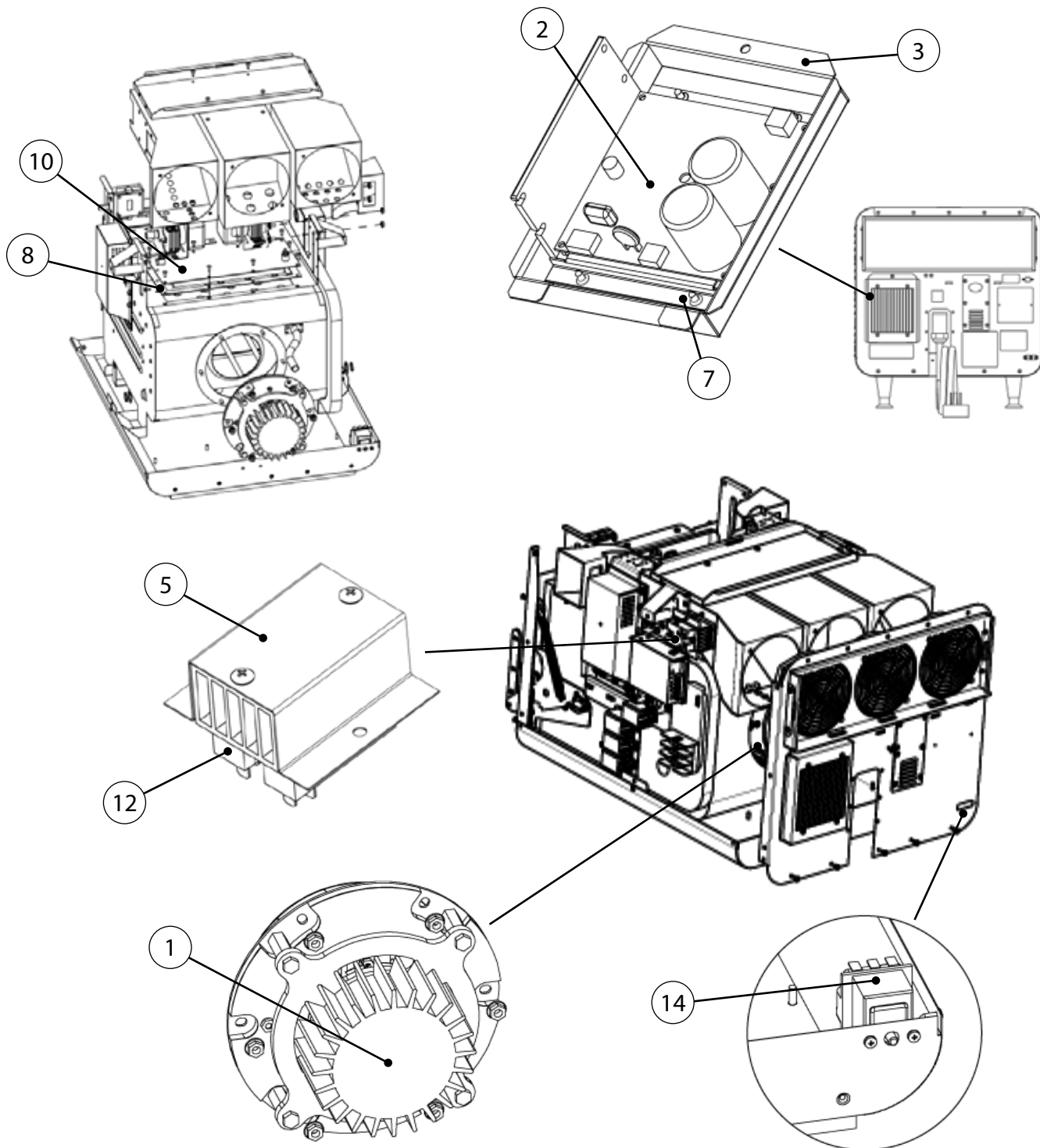
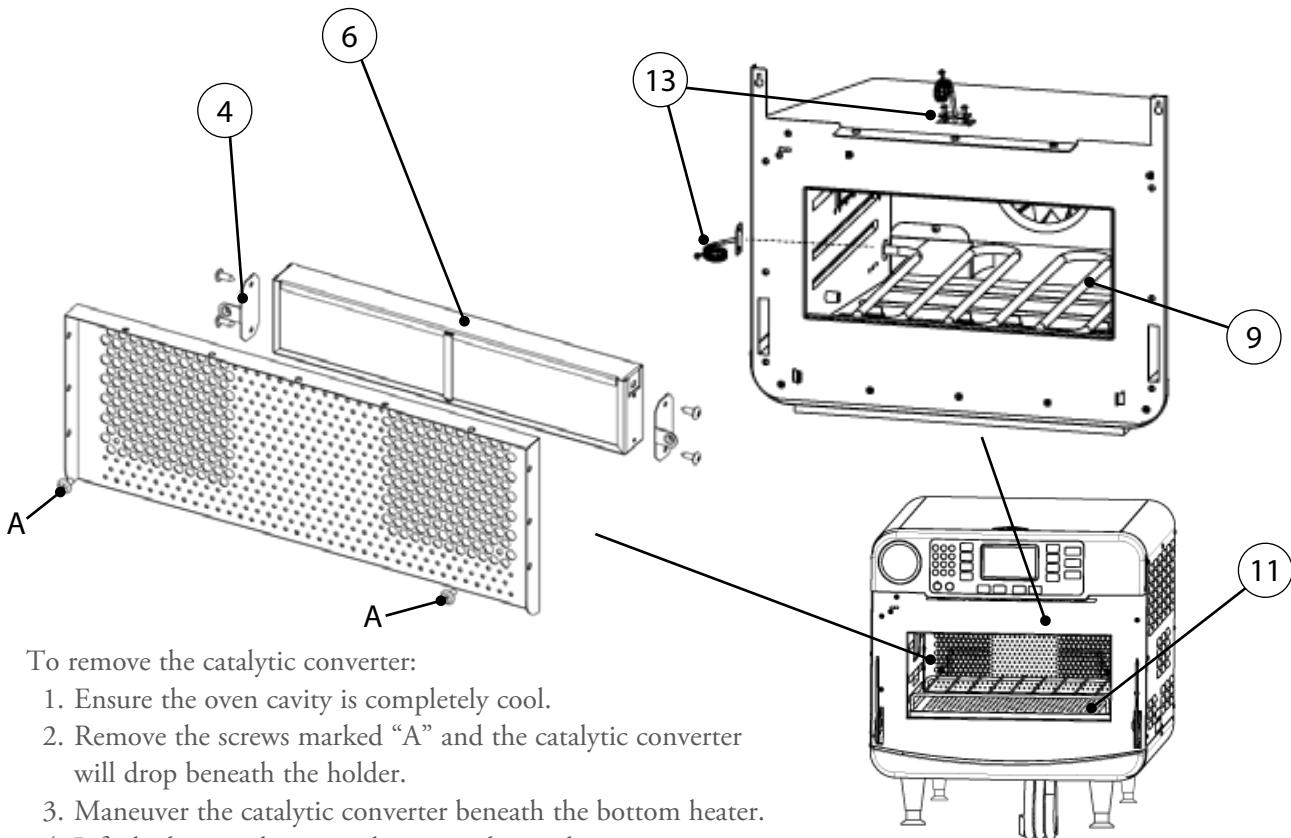

Figure Reference #	Item Description	Item Part Number	Fastener Description	Fastener Part Number
1	Blower Motor	NGC-1025	Nut, 1/4 - 20, Serr Hex Flange, Plated	100906 (qty 6)
2	Blower Motor Speed Controller	CON-3010	Screw, #8 x 1/2, Serr Ph Truss Hd, Sheet Mtl	101688 (qty 1)
3	Bracket, BMSC	HHB-8268	Screw, #8 x 1/2, Serr Ph Truss Hd, Sheet Mtl	101688 (qty 4)
4	Bracket, Catalytic Converter (qty 2)	ENC-1148	Screw, #8 x 3/8, Ph Mod Truss Hd, Cres	101682 (1 per)
5	Bracket, Solid State Relay	ENC-1102	Screw, #8 x 1/2, Serr Ph Truss Hd, Sheet Mtl	101688 (qty 2)
6	Catalytic Converter	ENC-1147	Screw, #8 x 1/2, Serr Ph Truss Hd, Sheet Mtl	101688 (qty 4)
7	Clip, BMSC Bracket (x2)	HHB-8269	Screw, #8 x 1/2, Serr Ph Truss Hd, Sheet Mtl	101688 (qty 2 each)
8	Gasket, Heater, Top	NGC-1043	Screw, #8 x 1/2, Serr Ph Truss Hd, Sheet Mtl	101688 (qty 10)
9	Heater, Bottom	ENC-3002	Retaining Ring, .750" ID, SS, Series SH Washer, Shim, .752" x 1.12" x .033"	101312 (qty 2) 102449 (qty 2)
10	Heater, Top	NGC-3011	Screw, #8 x 1/2, Serr Ph Truss Hd, Sheet Mtl	101688 (qty 10)
11	Jetplate, Bottom	ENC-1066	None	None
12	Relay, Solid State (K4/K5 - Heaters)	101286	Screw, #8 x 1/2, Serr Ph Truss Hd, Sheet Mtl	101688 (qty 2)
13	RTD, Cook Cavity, 3" (x2)	HHC-6517-2	Screw, #8 x 1/2, Serr Ph Truss Hd, Sheet Mtl	101688 (qty 2 / heater)
14	Thermostat, High-Limit, 300°C	102075	Screw, M4 x 0.7 x 8, PPHD, Int Tooth, SS	101672 (qty 2)



To remove the catalytic converter:

1. Ensure the oven cavity is completely cool.
2. Remove the screws marked "A" and the catalytic converter will drop beneath the holder.
3. Maneuver the catalytic converter beneath the bottom heater.
4. Lift the bottom heater and remove the catalytic converter.

Microwave System



DANGER: Lethal voltage is present while the microwave circuit is on. Before servicing any oven part, be sure the oven has completed “cooling down” (see “Step 9” on page 11) and is removed from the power source.

NOTE: For clarity, some components have been removed from the illustrations below.

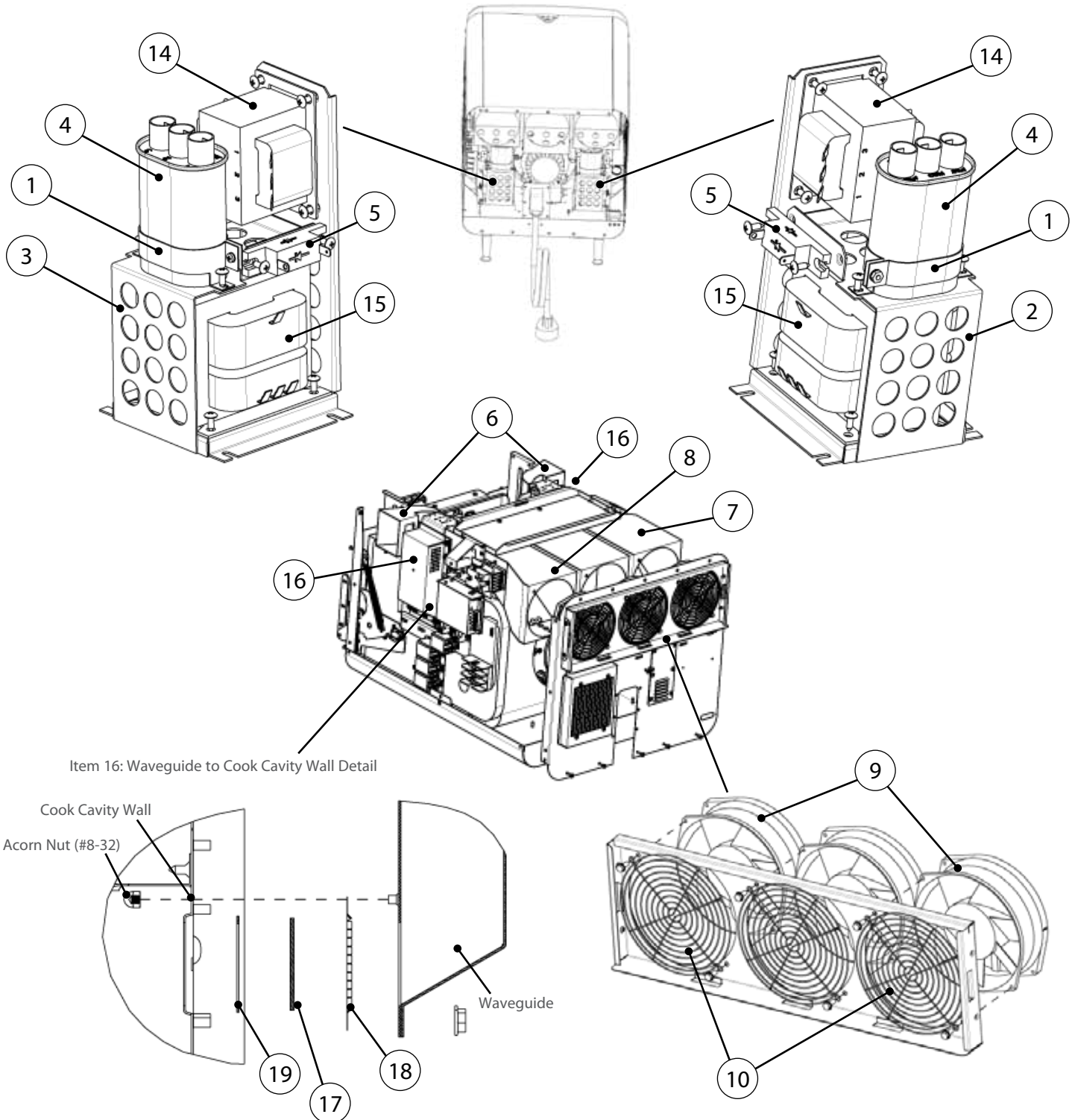
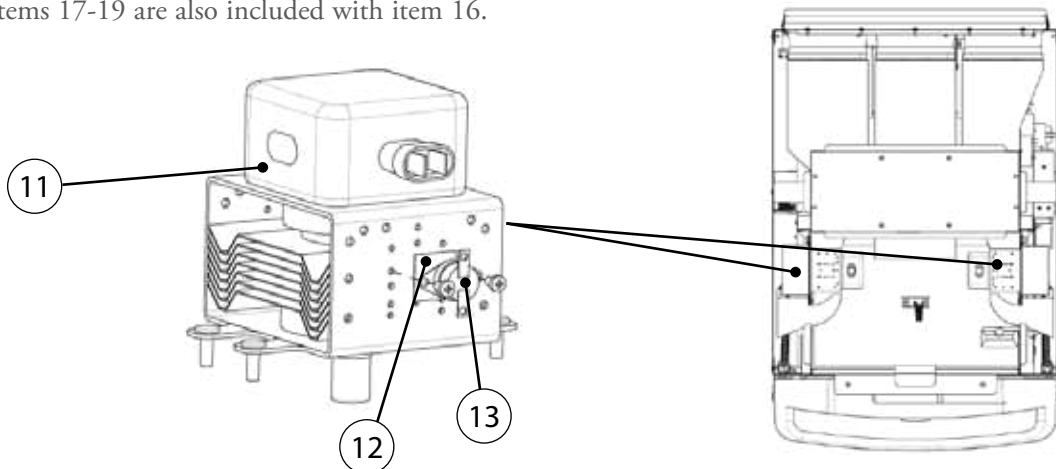

Figure Reference #	Item Description	Item Part Number	Fastener Description	Fastener Part Number
1	Bracket, Capacitor (x2)	100134	Screw, #6-32 x 3/8, Int Tooth, PPH, SS	102911 (qty 1 each)
2	Bracket, HV Components, Right	ENC-1161	Nut, #10-32, Keps, Ext Tooth, SS	102963 (qty 2)
3	Bracket, HV Components, Left	ENC-1167	Nut, #10-32, Keps, Ext Tooth, SS	102963 (qty 2)
4	Capacitor, .91 uf, 2500 VAC (x2)	100232	Bracket, Capacitor	See Item 1
5	Diode, High Voltage (x2)	100481	Screw, #8 x 1/2, Serr Ph Truss Hd, Sheet Mtl	101688 (qty 2 each)
6	Duct, Cooling, Magnetron, Out (x2)	ENC-1036	None	None
7	Duct, Cooling Fan, Left	ENC-1037	Screw, #8 x 1/2, Serr Ph Truss Hd, Sheet Mtl	101688 (qty 4)
8	Duct, Cooling Fan, Right	ENC-1033	Screw, #8 x 1/2, Serr Ph Truss Hd, Sheet Mtl	101688 (qty 6)
9	Fan, Cooling, Magnetron (x2)	TC3-0433	Screw, #10-32 x 1/2, Hex Wshr Hd, Type 23	101408 (qty 2 each)
10	Finger Guard, Cooling Fans (x2)	100086	Screw, #10-32 x 1/2, Hex Wshr Hd, Type 23	101408 (qty 2 each)
Not Shown	Jumper, Capacitor (Intl only) (x2)	i5-9378	None	None
11	Magnetron (x2)	NGC-3015	Nut, #10-32, Serr Hex Flange, Zinc	100913 (qty 4 each)
12	Pad, Insulator, Mag Thermostat (x2)	NGC-1163	Screw, #6 x 3/8, PPHD, Drill Point, Zinc	101684 (qty 2 each)
See page A14	Relay (K1 - Filament)	101273	Nut, #6-32, Keps Hex, Ext Tooth, Cres	102961 (qty 2)
See page A14	Relay (K2 - Anode)	101273	Nut, #6-32, Keps Hex, Ext Tooth, Cres	102961 (qty 2)
See page A14	Relay (K7 - Magnetron Cooling Fan)	101274	Nut, #6-32, Keps Hex, Ext Tooth, Cres	102961 (qty 2)
13	Thermostat, Magnetron (x2)	104228	Screw, #6 x 3/8, PPHD, Drill Point, Zinc	101684 (qty 2 each)
14	Transformer, Filament, 60 Hz (x2) Transformer, Filament, 50 Hz (x2)	NGC-3061-1 NGC-3061-2	Screw, #8 x 1/2, Serr Ph Truss Hd, Sheet Mtl	101688 (qty 4 each)
15	Transformer, HV, 60 Hz (x2) Transformer, HV, 50 Hz (x2)	NGC-3062-1 NGC-3062-2	Screw, #8 x 1/2, Serr Ph Truss Hd, Sheet Mtl	101688 (qty 4 each)
16	Waveguide Kit (x2)*	ENC-3008	Included	Included
17	Waveguide Cover (x2)	i1-9462	None	None
18	Waveguide Gasket (x2)*	i1-9331	Nut, #10-32, Serr Hex Flange, Zinc	100913 (qty 9 each)
19	Waveguide Seal (x2)*	i1-9486	None	None
Not Shown	Harness, Wiring, HV, MW Circuit 1	ENC-1208-1	None	None
Not Shown	Harness, Wiring, HV, MW Circuit 2	ENC-1208-2	None	None

* Items 17-19 are also included with item 16.



Oven Door and Related Parts

⚠ DANGER: Before removing any oven part, be sure the oven has completed “cooling down” (see “Step 9” on page 11) and is removed from the power source.

NOTE: For clarity, some components have been removed from the illustrations below.

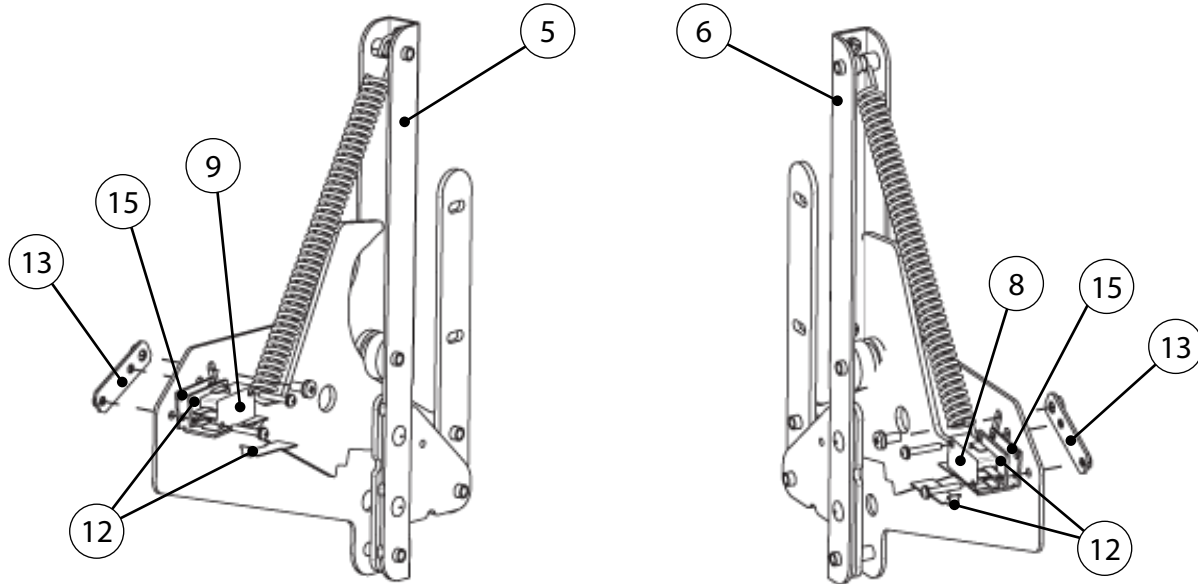

* When replacing the primary switch:

- a.) Discard one of the switches supplied with kit [NGC-3033](#)
- b.) Use the shorter screws (see Figure below)
- c.) Follow all instructions in the provided field service bulletins FSB-10057 and FSB-10094
- d.) Discard FSB-10055

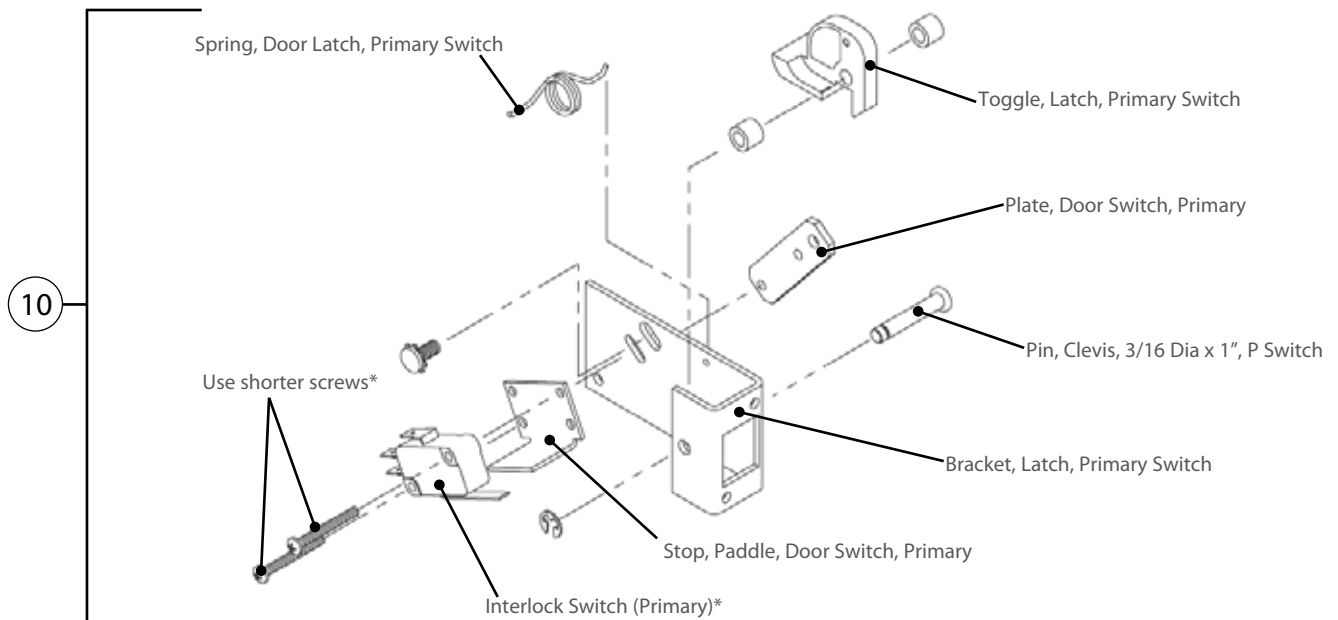
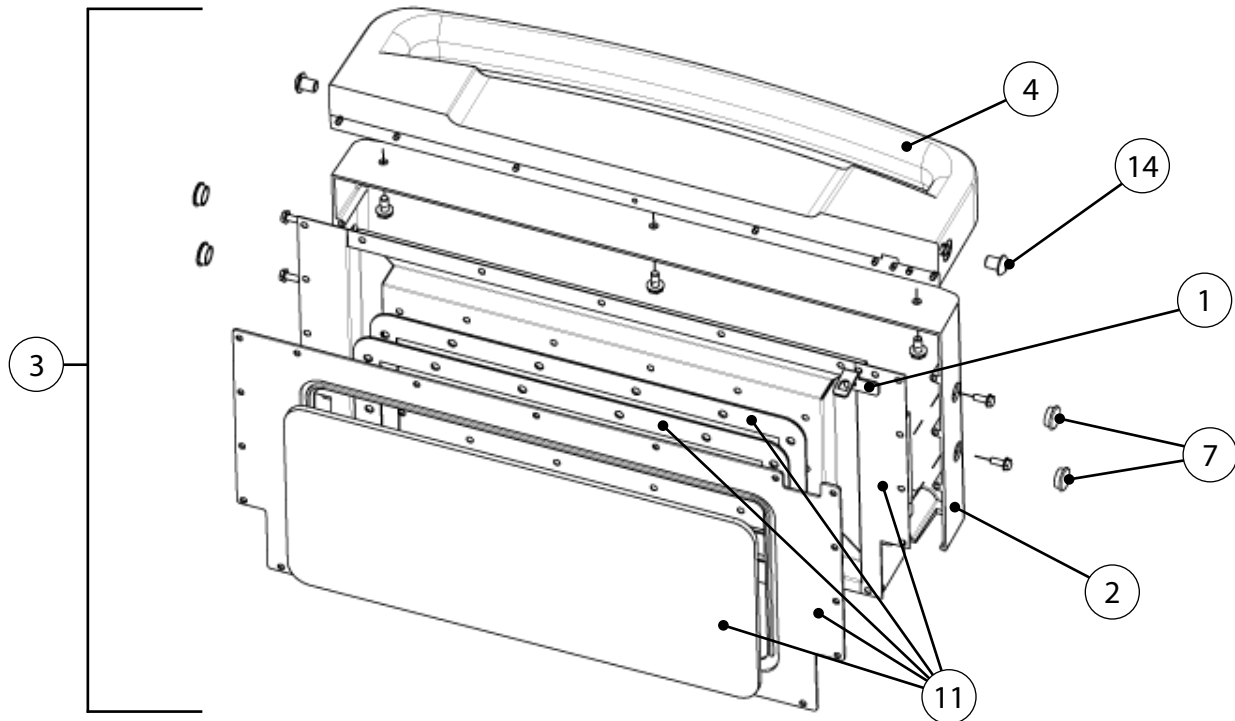



Figure Reference #	Item Description	Item Part Number	Fastener Description	Fastener Part Number
See page A2	Badge, Logo, Encore/ Encore 2	ENC-1192	Nut, Push, 1/8	101293 (qty 2)
1	Catch, Latch	ENC-1131	Screw, #8 x 3/8, Security, Torx Hd	102748 (qty 2)
2	Cover, Door, Gray	ENC-1121-T001	Screw, #8 x 5/8, Ph Mod Truss Hd, Cres	101376 (qty 11)
3	Door, Entire Assembly	ENC-3003	Screw, #10-32 x 1/2, Hex, Serr, Zinc	101373 (qty 4)
4	Handle, Door, Black	ENC-1122-9005	Screw, #8 x 5/8, Ph Mod Truss Hd, Cres	101376 (qty 7)
5	Hinge, Left	i1-3220-1	Screw, #8-32 x 5/8, PFH, 100 Deg, SS	102811 (qty 3)
6	Hinge, Right	i1-3220-2	Screw, #8-32 x 5/8, PFH, 100 Deg, SS	102811 (qty 3)
7	Hole Plug, Black, 5/8" Dia (x4)	101195	None	None
8	Interlock Switch (Monitor)	102013	Screw, #4-40 x 3/4, Sems, PPHD, SS	102904 (qty 2)
9	Interlock Switch (Secondary)	102013	Screw, #4-40 x 3/4, Sems, PPHD, SS	102904 (qty 2)
10	Kit, Door Switch, Primary*	NGC-3033*	Included with Kit	Included with Kit
11	Kit, Shunt Plate	ENC-3007	Included with Kit	Included with Kit
12	Kit, Switch Offset, Shim and Replacement Tab (x2)	i1-3207	Screw, #4-40 x 3/4, Sems, PPHD, SS	102904 (qty 2)
13	Plate, Door Switch, S/M (x2)	NGC-1126	Screw, #4-40 x 3/4, Sems, PPHD, SS Screw, #8-32 x 3/8, PPHD, Int Sems, SS	102904 (qty 2 each) 102921 (qty 1 each)
See page A14	Relay (K3 - Monitor)	101273	Nut, #6-32, Keps Hex, Ext Tooth, Cres	102961 (qty 2)
14	Screw, Door, Buttonhead (x2)	ENC-1220	None	None
15	Stop, Paddle, Door Switch, S/M (x2)	NGC-1324	Screw, #4-40 x 3/4, Sems, PPHD, SS	102904 (qty 2 each)



Control System

 **DANGER:** Before removing any oven part, be sure the oven has completed “cooling down” (see “Step 9” on page 11) and is removed from the power source.

NOTE: For clarity, some components have been removed from the illustrations below.

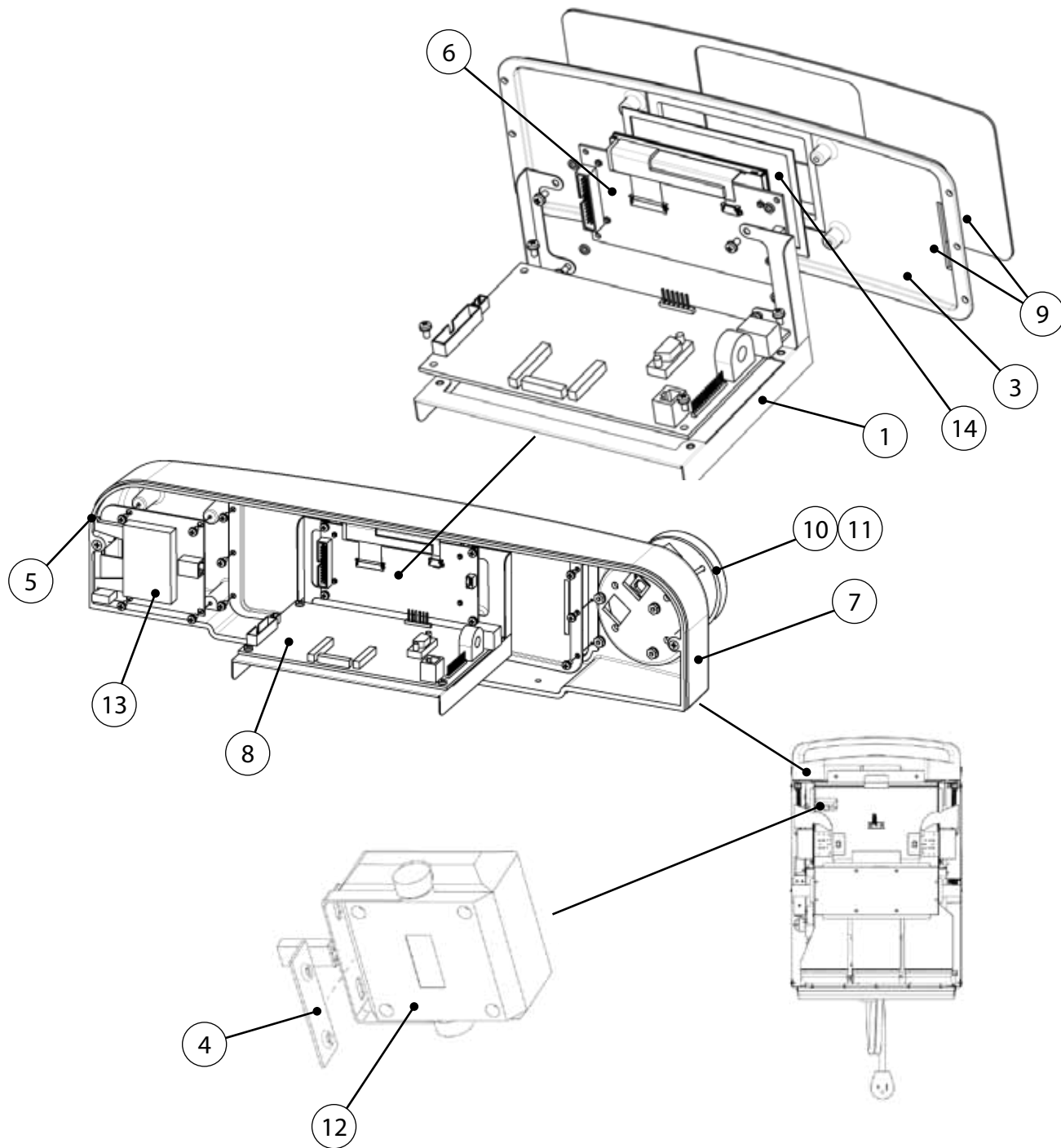
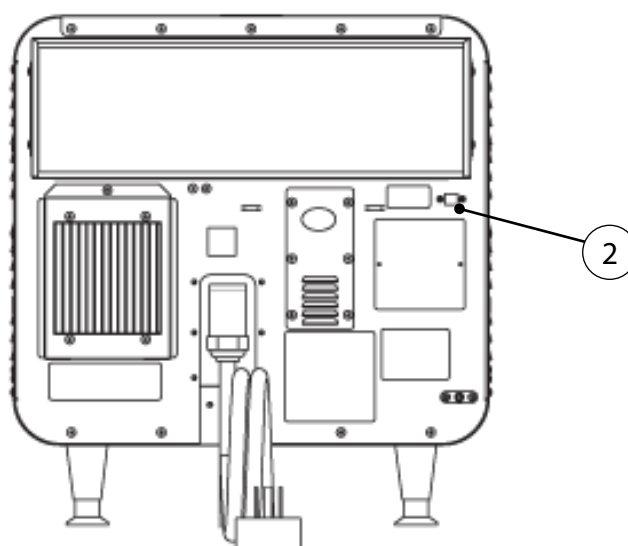

Figure Reference #	Item Description	Item Part Number	Fastener Description	Fastener Part Number
1	Bracket, Control Board, Support	ENC-1098	Screw, #6-32 x 1/4", Int Tooth, PPH, SS	102910 (qty 4)
Not Shown	Cable, Display, 5"	ENC-1311	None	None
2	Cable, Extension, Ethernet	100164	Screw, #4-40 x .25, PPH Sems Int Tooth, SS	101520 (qty 2)
Not Shown	Cable, Control Board to Light Ring	ENC-1312	None	None
Not Shown	Cable, Light Ring to USB/Card Reader	100182	None	None
3	Casting, Keypad	ENC-1116	Screw, #6-32 x 1/4", Int Tooth, PPH, SS	102910 (qty 6)
4	Clip, Speaker Mounting	HCT-4104	Screw, #8 x 1/2, Serr Ph Truss Hd, Sheet Mtl	101688 (qty 2)
5	Cover, USB Port	ENC-1189	None	None
6	Display	ENC-3011	Screw, #6-32 x 1/4", Int Tooth, PPH, SS Washer, #6-32, Neoprene	102910 (qty 4) 102439 (qty 4)
7	Housing, Display and Controls	ENC-1101	Screw, #8-32 x 3/8", PFH, 100 Deg, SS Screw, #8-32 x 5/8", PFH, 100 Deg, SS	102809 (qty 3) 102811 (qty 2)
8	Kit, Control Board	CON-3006*	Screw, #6-32 x 1/4", Int Tooth, PPH, SS	102910 (qty 4)
9	Kit, Keypad	ENC-3004**	Screw, #6-32 x 1/4", Int Tooth, PPH, SS	102910 (qty 6)
10	Kit, Light Ring (TurboChef)	ENC-3005-1	Nut, #6-32, Keps Hex, Ext Tooth, Cres	102961 (qty 4)
11	Kit, Light Ring (SUBWAY®)	ENC-3005-2	Nut, #6-32, Keps Hex, Ext Tooth, Cres	102961 (qty 4)
12	Kit, Speaker	CON-3003	Screw, #8 x 1/2, Serr Ph Truss Hd, Sheet Mtl	101688 (qty 2)
13	USB/Smart Card Reader	CON-7005	Screw, #6-32 x 1/4", Int Tooth, PPH, SS	102910 (qty 4)
14	Window, Display	ENC-1191	None	None
Not Shown	Wire, Display Jumper, 3-Pin	i1-9475	None	None
Not Shown	Harness, Wiring, Low Voltage	ENC-1210	None	None

* See Service Parts Price List for details.

** ENC-3004 (item 9) includes item 3.



Power Components

⚠ DANGER: Before removing any oven part, be sure the oven has completed “cooling down” (see “Step 9” on page 11) and is removed from the power source.

NOTE: For clarity, some components have been removed from the illustrations below.

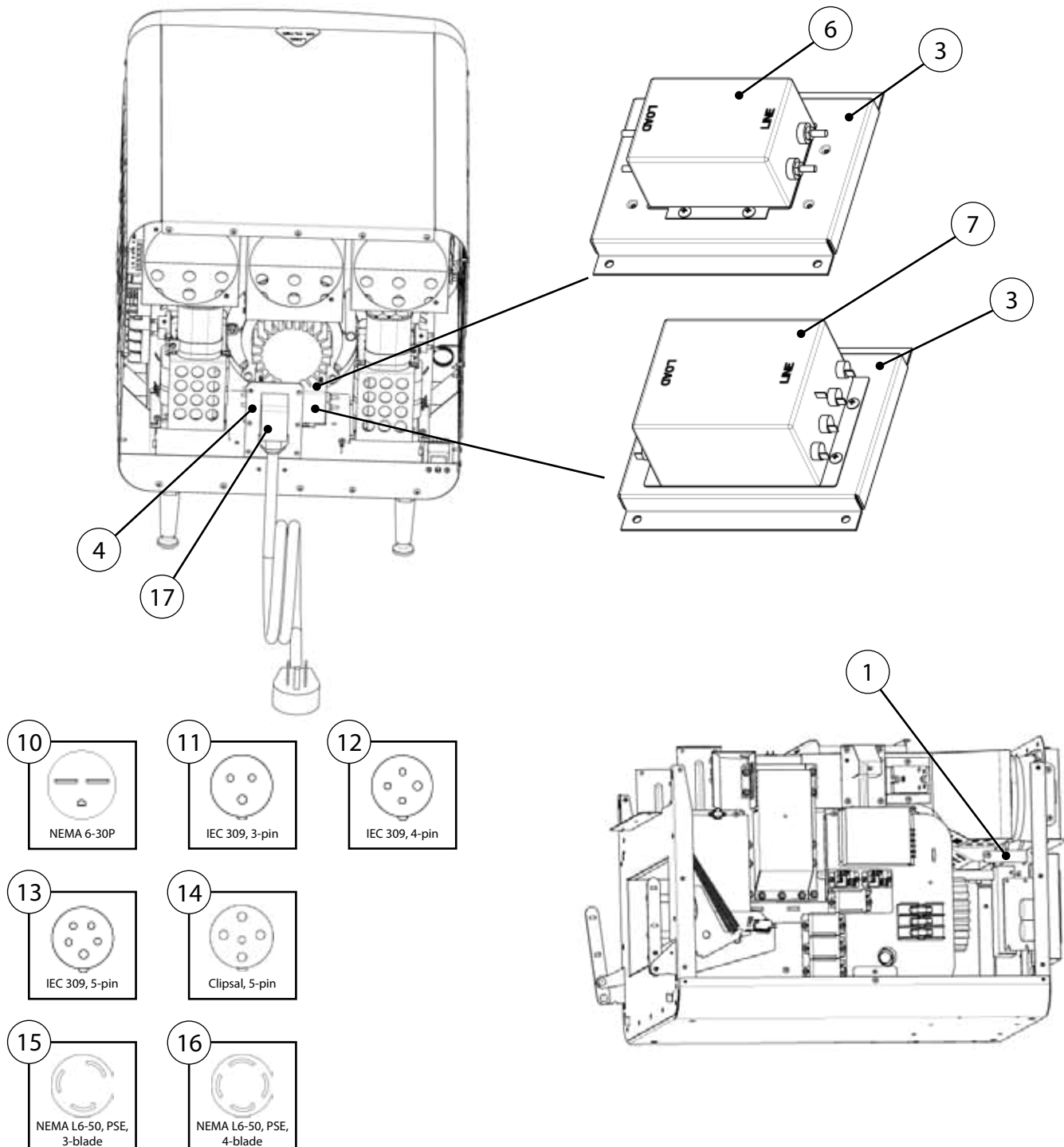
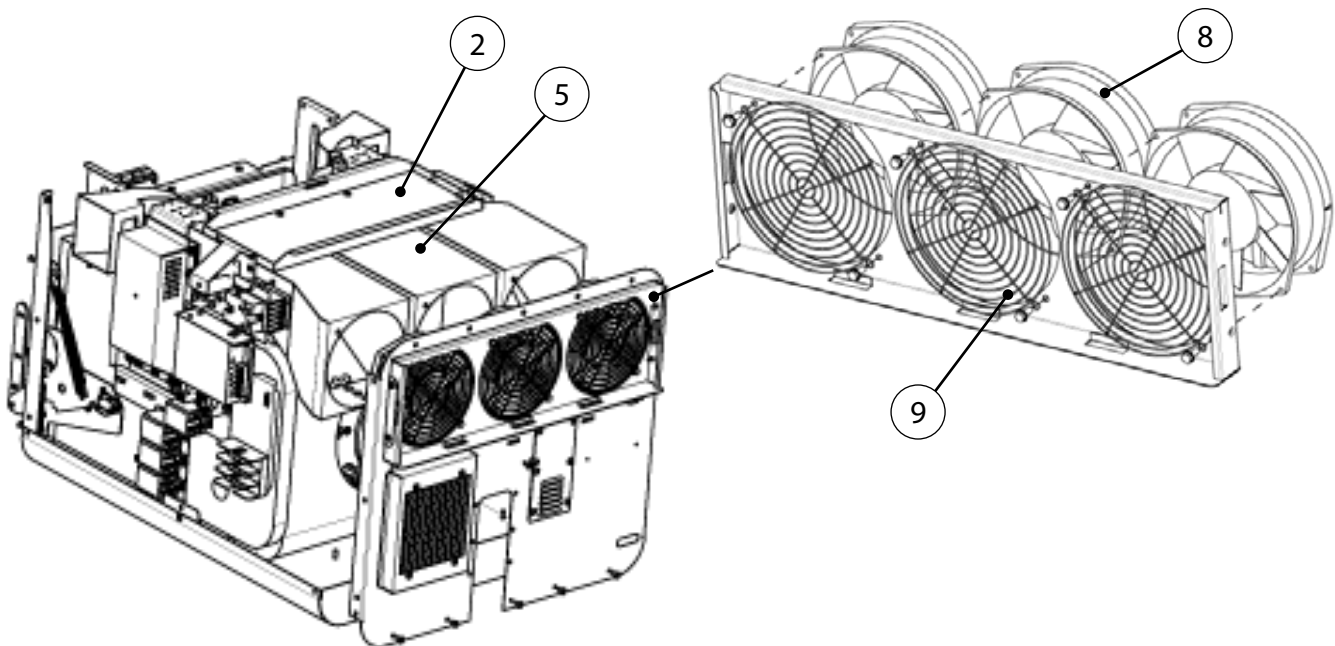



Figure Reference #	Item Description	Item Part Number	Fastener Description	Fastener Part Number
1	Bracket, Back Wall Support (Bracket Only)	ENC-1170	Screw, #8 x 3/8, Ph Mod Truss Hd, Cres	101682 (qty 2)
2	Bracket, Cooling Duct, Center	ENC-1096	Screw, #8 x 1/2, Serr Ph Truss Hd, Sheet Mtl	101688 (qty 4)
3	Bracket, EMI Mounting	ENC-1207	Screw, #8 x 1/2, Serr Ph Truss Hd, Sheet Mtl	101688 (qty 4)
4	Bracket, Power Cord	ENC-1164	Screw, #8 x 3/8, Ph Mod Truss Hd, Cres	101682 (qty 8)
5	Duct, Cooling, Electrical Compartment	ENC-1038	Screw, #8 x 1/2, Serr Ph Truss Hd, Sheet Mtl	101688 (qty 5)
6	EMI Filter, 1 Ph	100543	Screw, #8 x 1/2, Serr Ph Truss Hd, Sheet Mtl	101688 (qty 2)
7	EMI Filter, 3 Ph	100547	Screw, #8 x 1/2, Serr Ph Truss Hd, Sheet Mtl	101688 (qty 4)
8	Fan, Cooling, Electrical Compartment	TC3-0433	Screw, #10-32 x 1/2, Hex Wshr Hd, Type 23	101408 (qty 2 each)
9	Finger Guard	100086	Screw, #10-32 x 1/2, Hex Wshr Hd, Type 23	101408 (qty 2 each)
10	Power Cord, 60 Hz, 208-240 VAC, 1 Ph	100187	Nut, #10-32, Keps, Ext Tooth, SS	102963 (qty 3)
11	Power Cord, 50 Hz, 220-230 VAC, 1 Ph	100195	Nut, #10-32, Keps, Ext Tooth, SS	102963 (qty 3)
12	Power Cord, 50/60 Hz, 220-230 VAC, 3 Ph	100194	Nut, #10-32, Keps, Ext Tooth, SS (or provided 90 deg spade terminals)	102963 (qty 4)
13	Power Cord, 50/60 Hz, 380-415 VAC, 3 Ph	103187	Nut, #10-32, Keps, Ext Tooth, SS (or provided 90 deg spade terminals)	102963 (qty 5)
14	Power Cord, Aus/NZ, Clipsal, 400V, 3Ph	103195	Nut, #10-32, Keps, Ext Tooth, SS (or provided 90 deg spade terminals)	102963 (qty 5)
15	Power Cord, Japan, 1 Ph	NGC-1390	Nut, #10-32, Keps, Ext Tooth, SS	102963 (qty 3)
16	Power Cord, Japan, 3 Ph	NGC-1383	Nut, #10-32, Keps, Ext Tooth, SS (or provided 90 deg spade terminals)	102963 (qty 4)
17	Strain Relief, Rt Angle	100423	Nut, Mounting, Strain Relief	100424

See pages A-14 and A-15 for more power components.



Power Components, Continued

 **DANGER:** Before removing any oven part, be sure the oven has completed “cooling down” (see “Step 9” on page 11) and is removed from the power source.

NOTE: For clarity, some components have been removed from the illustrations below.

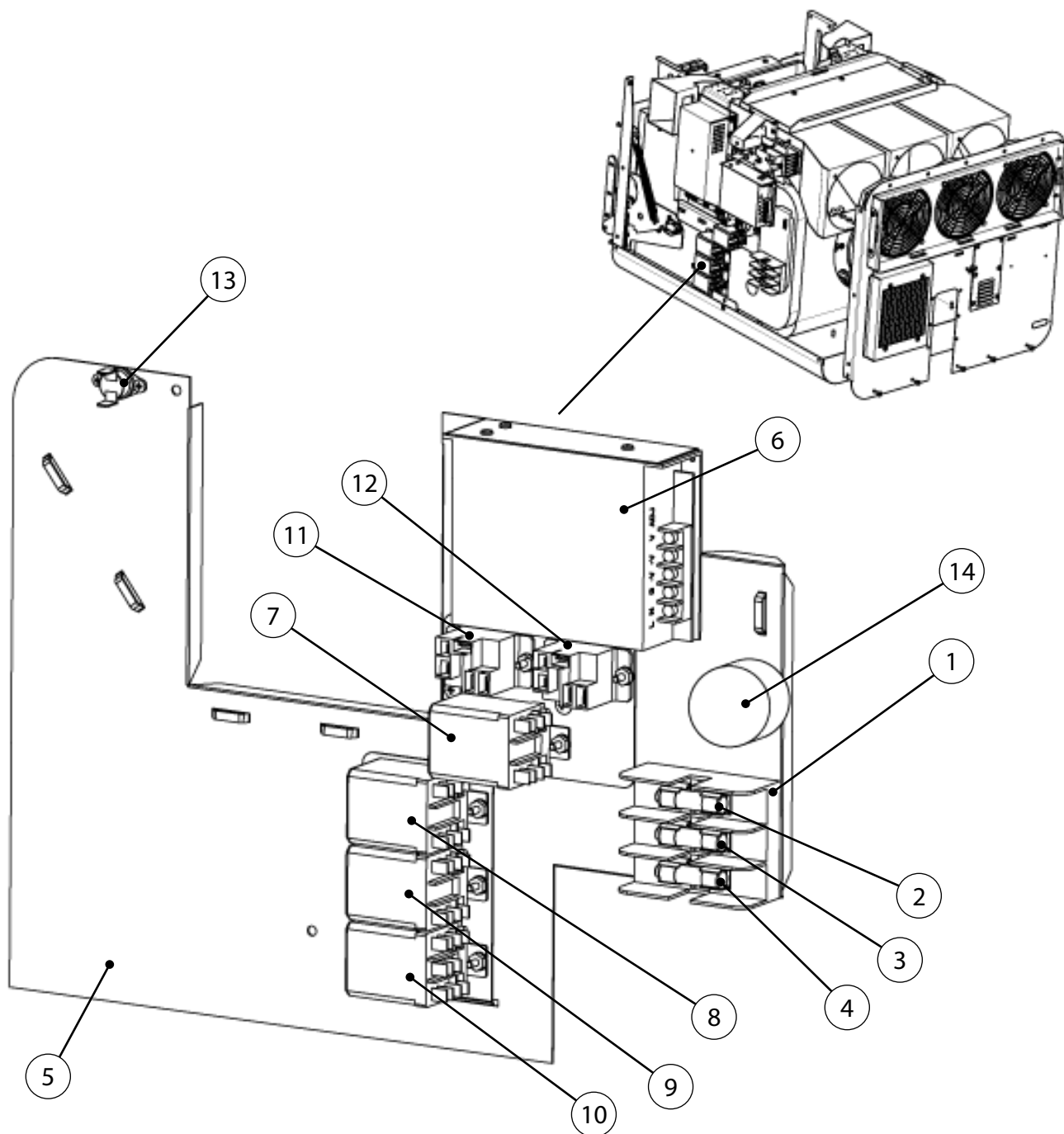

Figure Reference #	Item Description	Item Part Number	Fastener Description	Fastener Part Number
1	Fuse Block, 3 Pole, 30 Amp	103566	Screw, #8 x 1/2, Serr Ph Truss Hd, Sheet Mtl	101688 (qty 2)
2	Fuse, F1, 12 amp, Class CC, ATMR	100592	None	None
3	Fuse, F2, 12 amp, Class CC, ATMR	100592	None	None
4	Fuse, F3, 20 amp, Class CC, ATMR	100599	None	None
5	Panel, Electrical, RHS (Panel Only)	ENC-1019	Screw, #8 x 1/2, Serr Ph Truss Hd, Sheet Mtl	101688 (qty 3)
6	Power Supply, 24 VDC	101211	Screw, M3 x 8mm, PPH, Sems, Cres	103444 (qty 3)
7	Relay (K1 - Filament)	101273	Nut, #6-32, Keps Hex, Ext Tooth, Cres	102961 (qty 2)
8	Relay (K2 - Anode)	101273	Nut, #6-32, Keps Hex, Ext Tooth, Cres	102961 (qty 2)
9	Relay (K3 - Monitor)	101273	Nut, #6-32, Keps Hex, Ext Tooth, Cres	102961 (qty 2)
10	Relay (K6 - Voltage)	101272	Nut, #6-32, Keps Hex, Ext Tooth, Cres	102961 (qty 2)
11	Relay (K7 - Magnetron Cooling Fan)	101274	Nut, #6-32, Keps Hex, Ext Tooth, Cres	102961 (qty 2)
12	Relay (K8 - EC Fan)	101274	Nut, #6-32, Keps Hex, Ext Tooth, Cres	102961 (qty 2)
13	Thermostat, Cooling Fan, EC, 120F	102086	Screw, #6 x 3/8, PPHD, Drill Point, Zinc	101684 (qty 2)
14	Voltage Sensor (North America only)	100783	Screw, #8 x 1/2, Serr Ph Truss Hd, Sheet Mtl	101580 (qty 1)
Not Shown	Harness, Wiring, Heater	ENC-1212	None	None
Not Shown	Harness, Wiring, Cooling Fan	ENC-1213	None	None
Not Shown	Harness, Wiring, Line Voltage	ENC-1214	None	None

*This page intentionally
left blank.*

Encore 2 Appendix: Replacing Oven Components

(see page A-1 for Encore)

Replacing Oven Components

This appendix provides illustrations for removing serviceable items, as well as the item numbers and descriptions for those items. It also includes the item numbers and descriptions for the fasteners used to secure each component to the oven chassis.

The appendix is divided into the following sections:

- Oven Exterior (pages A-18 through A-19)
- Impingement System (pages A-20 through A-21)
- Microwave System (pages A-22 through A-23)
- Oven Door and Related Parts (A-24 through A-25)
- Control System (A-26 through A-27)
- Power Components (A-28 through A-31)

If you have any questions that are not addressed in this manual or appendix, please contact TurboChef Customer Service at 800.90TURBO or +1 214.379.6000.

Oven Exterior

⚠ DANGER: Before removing any oven part, be sure the oven has completed “cooling down” (see “Step 9” on page 11) and is removed from the power source.

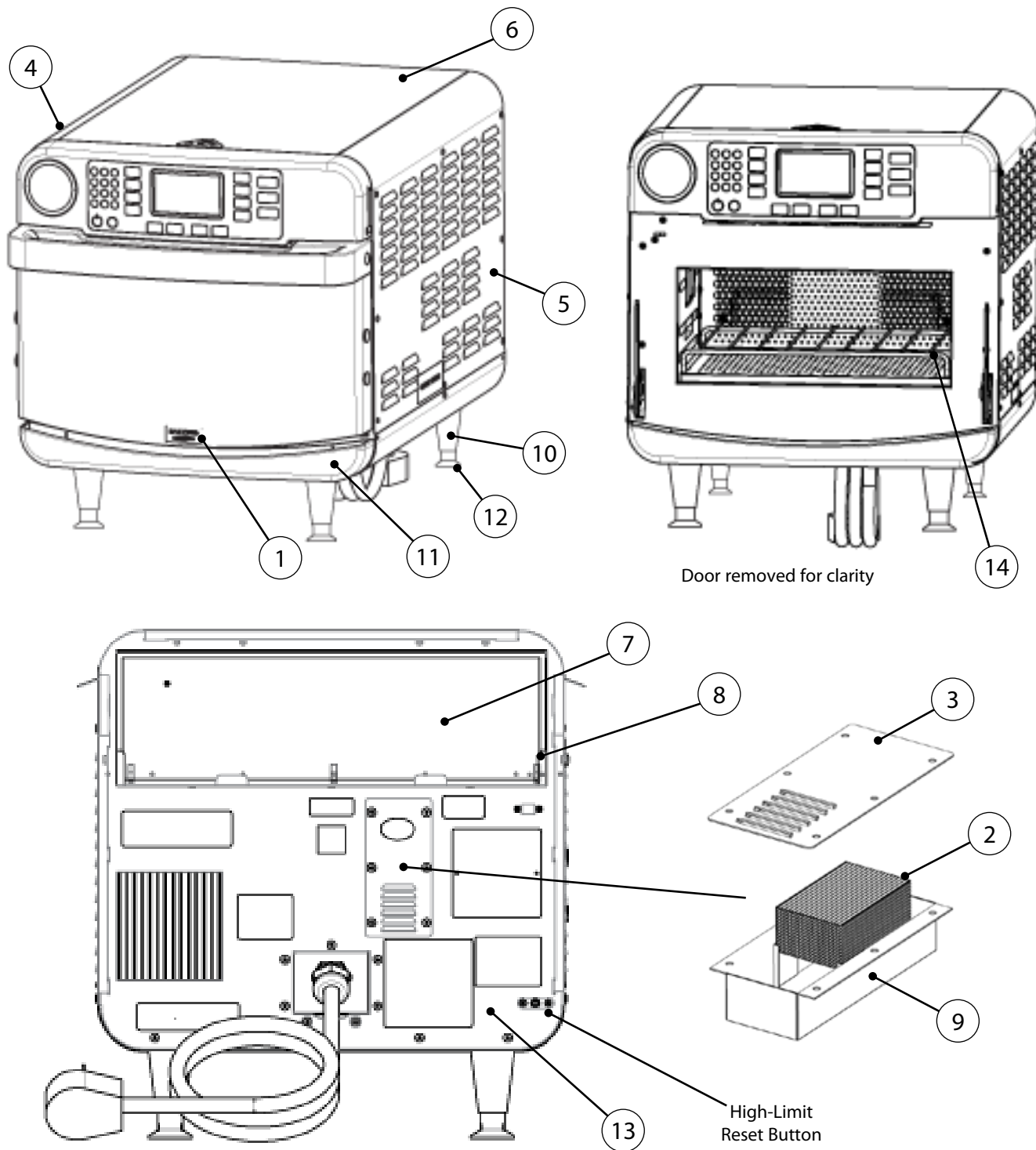

Figure Reference #	Item Description	Item Part Number	Fastener Description	Fastener Part Number(s)
1	Badge, Logo, Encore/ Encore 2	ENC-1192	Nut, Push, 1/8"	101293 (qty 2)
2	Catalytic Converter, Vent Tube	RWD-9191	None	None
3	Cover, Exhaust Tube	ENC-1080	Screw, #8 x 3/8, Ph Mod Truss Hd, Cres	101682 (qty 6)
4	Cover, Left Side, Black	ENC-1332-T010	Screw, #8-32 x 3/8, PPHD, Bk Oxide Screw, #8 x 1/2, Security, Torx Hd, Bk Oxide	102922 (qty 1) 102756 (qty 1)
5	Cover, Right Side, Black	ENC-1333-T010	Screw, #8-32 x 3/8, Security, Torx Hd, Bk Oxide Screw, #8 x 1/2, Security, Torx Hd, Bk Oxide	102751 (qty 1) 102756 (qty 1)
6	Cover, Top, Black	ENC-1131-T010	None	None
7	Filter, Air	ENC-1114	None	None
8	Filter Bracket	ENC-1389	Screw, #8 x 1/2, Serr Ph Truss Hd, Sheet Mtl	101688 (qty 6)
9	Housing, Exhaust Tube	ENC-1079	Screw, #8 x 1/2, Serr Ph Truss Hd, Sheet Mtl	101688 (qty 6)
10	Leg, Plastic, Black (x4)	HHB-3205	None	None
11	Lower Front Panel	ENC-1103-T001	None	None
12	Pad, Abrasive, Non-Slip (x4)	NGC-1187	None	None
13	Panel, Rear	ENC-1334	Screw, #8 x 1/2, Serr Ph Truss Hd, Sheet Mtl	101688 (qty 5)
14	Rack, Oven	ENC-1216	None	None

Impingement System

⚠ DANGER: Before removing any oven part, be sure the oven has completed “cooling down” (see “Step 9” on page 11) and is removed from the power source.

NOTE: For clarity, some components have been removed from the illustrations below.

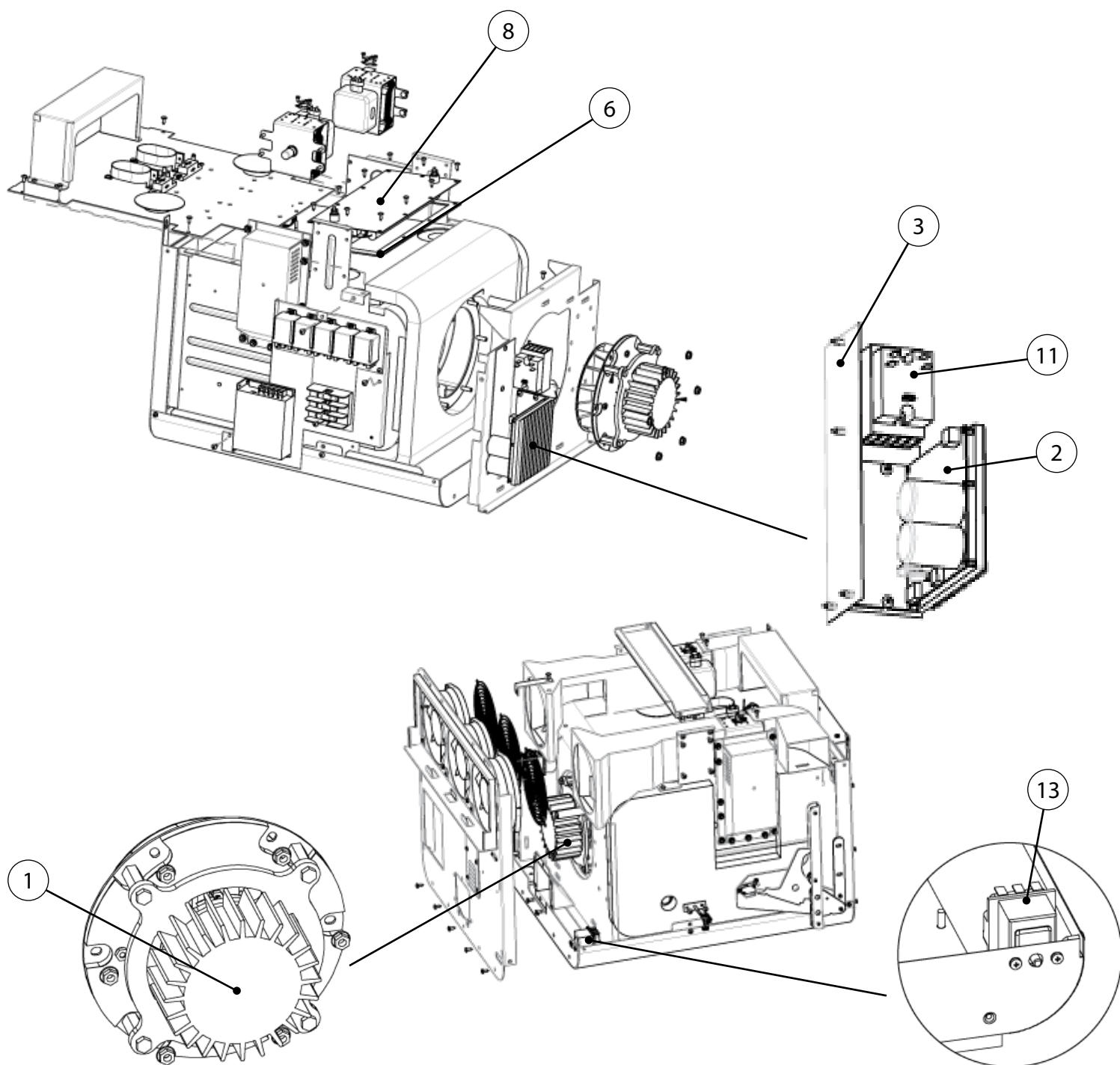
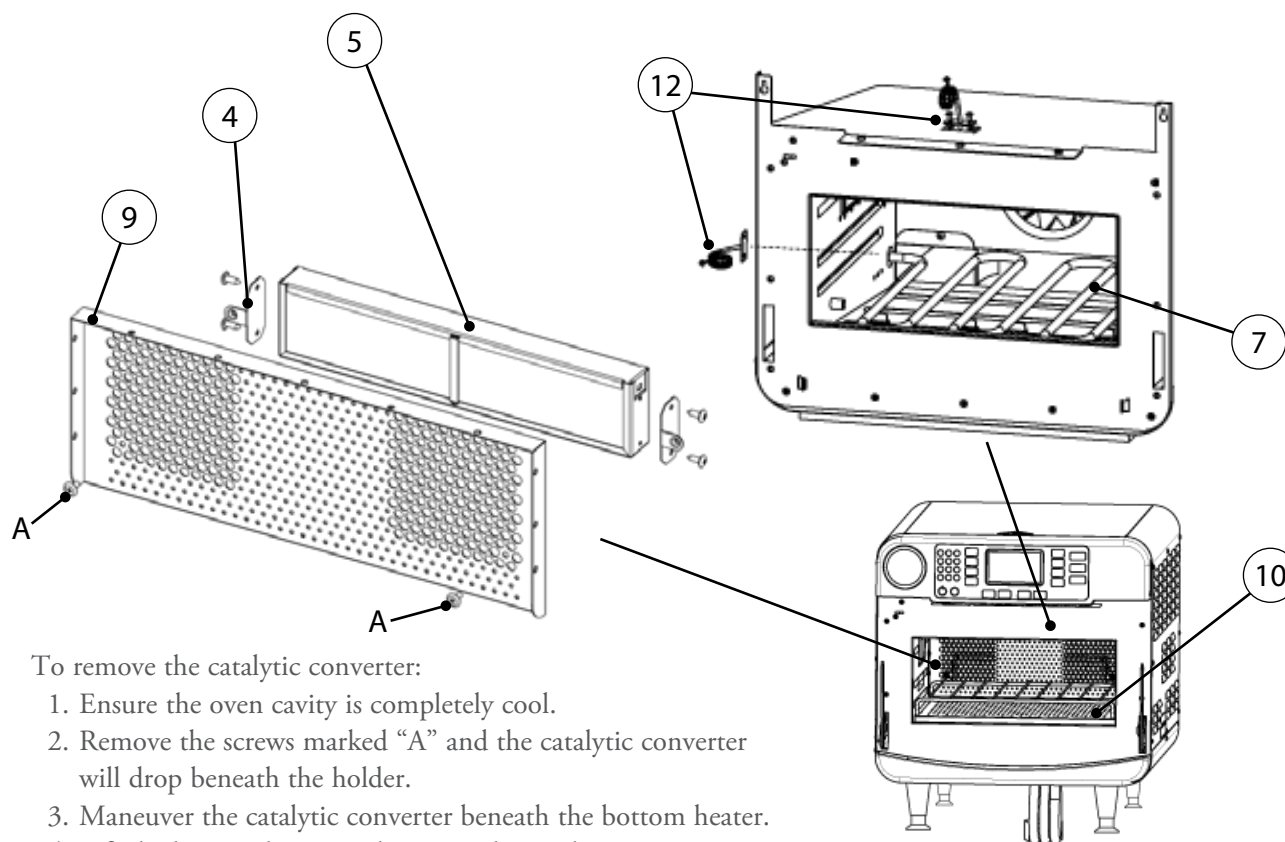

Figure Reference #	Item Description	Item Part Number	Fastener Description	Fastener Part Number
1	Blower Motor	NGC-1025	Nut, 1/4 - 20, Serr Hex Flange, Plated	100906 (qty 6)
2	Blower Motor Speed Controller	CON-3010	Screw, #8 x 1/2, Serr Ph Truss Hd, Sheet Mtl	101688 (qty 4)
3	Bracket, BMSC – SSR	ENC-1352	Screw, #8 x 1/2, Serr Ph Truss Hd, Sheet Mtl	101688 (qty 4)
4	Bracket, Catalytic Converter (qty 2)	ENC-1148	Screw, #8 x 1/2, Serr Ph Truss Hd, Sheet Mtl	101688 (2 per)
5	Catalytic Converter	ENC-1147	None	None
6	Gasket, Heater, Top	NGC-1043	Screw, #8 x 1/2, Serr Ph Truss Hd, Sheet Mtl	101688 (qty 10)
7	Heater, Bottom	ENC-3002	Retaining Ring, .750" ID, SS, Series SH Washer, Shim, .752" x 1.12" x .033"	101312 (qty 2) 102449 (qty 2)
8	Heater, Top	NGC-3011	Screw, #8 x 1/2, Serr Ph Truss Hd, Sheet Mtl	101688 (qty 10)
9	Holder, Catalytic Converter	ENC-1425	Screw, #8 x 1/2, Serr Ph Truss Hd, Sheet Mtl	101688 (qty 11)
10	Jetplate, Bottom	ENC-1066	None	None
11	Relay, Solid State (K4/K5 - Heaters)	101286	Screw, #8 x 1/2, Serr Ph Truss Hd, Sheet Mtl	101688 (qty 2)
12	RTD, Cook Cavity, 3" (x2)	HHC-6517-2	Screw, #8-32 x 1/4, Serr Ph Truss Hd, SS	101374 (qty 2 / heater)
13	Thermostat, High-Limit, 300°C	102075	Screw, M4 x 0.7 x 8, PPHD, Int Tooth, SS	101672 (qty 2)



To remove the catalytic converter:

1. Ensure the oven cavity is completely cool.
2. Remove the screws marked "A" and the catalytic converter will drop beneath the holder.
3. Maneuver the catalytic converter beneath the bottom heater.
4. Lift the bottom heater and remove the catalytic converter.

Microwave System

⚠ DANGER: Lethal voltage is present while the microwave circuit is on. Before servicing any oven part, be sure the oven has completed “cooling down” (see “Step 9” on page 11) and is removed from the power source.

NOTE: For clarity, some components have been removed from the illustrations below.

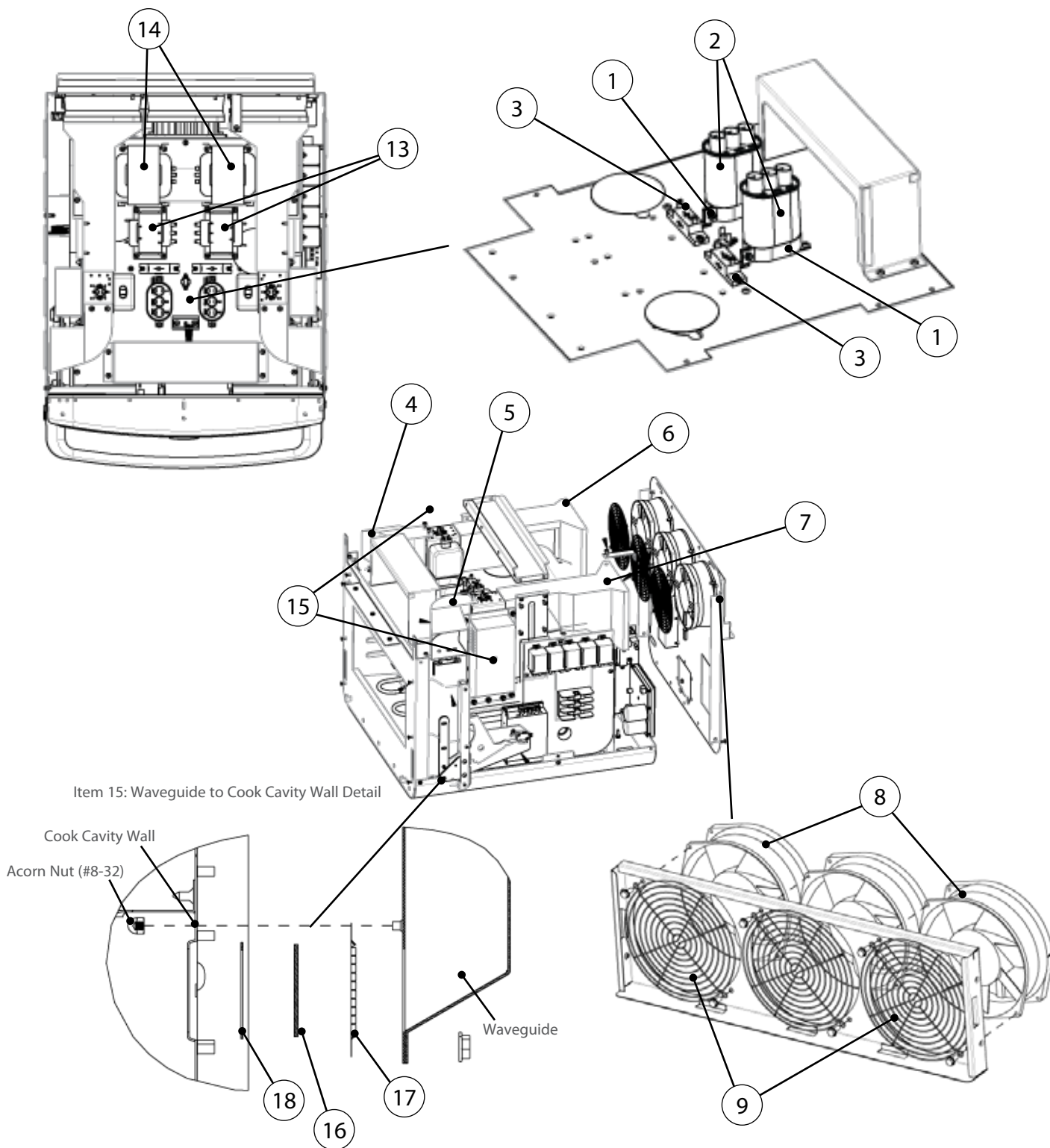
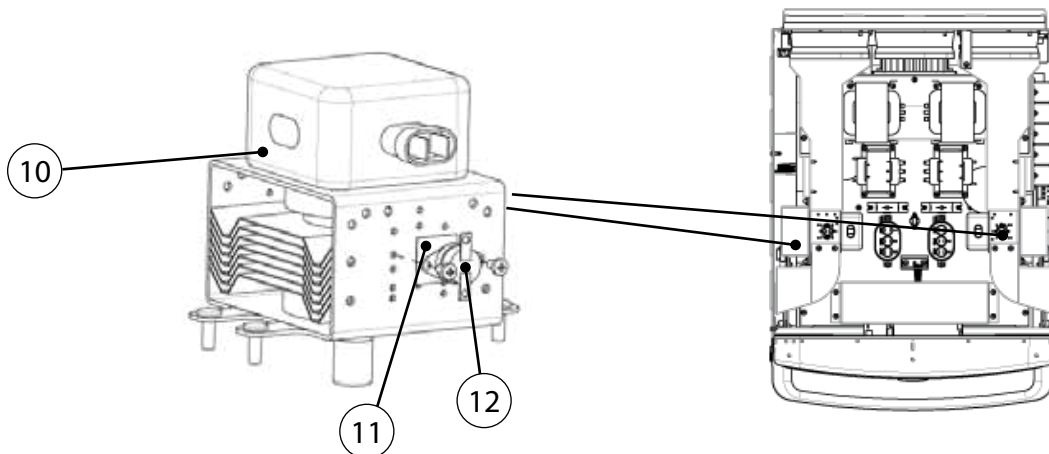

Figure Reference #	Item Description	Item Part Number	Fastener Description	Fastener Part Number
1	Bracket, Capacitor (x2)	100134	Screw, #8 x 1/2, Serr Ph Truss Hd, Sheet Mtl	101688 (qty 4)
2	Capacitor, .91 uf, 2500 VAC (x2)	100232	Bracket, Capacitor	See Item 1
3	Diode, High Voltage (x2)	100481	Screw, #8 x 1/2, PPHH, PLT	101689 (qty 2 each)
4	Duct, Cooling, Magnetron, Left	ENC-1373	None	None
5	Duct, Cooling, Magnetron, Right	ENC-1372	None	None
6	Duct, Cooling Fan, Left	ENC-1371	Screw, #8 x 1/2, Serr Ph Truss Hd, Sheet Mtl	101688 (qty 2)
7	Duct, Cooling Fan, Right	ENC-1370	Screw, #8 x 1/2, Serr Ph Truss Hd, Sheet Mtl	101688 (qty 2)
8	Fan, Cooling, Magnetron (x2)	TC3-0433	Screw, #10-32 x 1/2, Hex Wshr Hd, Type 23	101408 (qty 2 each)
9	Finger Guard, Cooling Fans (x2)	100086	Screw, #10-32 x 1/2, Hex Wshr Hd, Type 23	101408 (qty 2 each)
Not Shown	Jumper, Capacitor (Intl only) (x2)	i5-9378	None	None
10	Magnetron (x2)	NGC-3015	Nut, #10-32, Serr Hex Flange, Zinc	100913 (qty 4 each)
11	Pad, Insulator, Mag Thermostat (x2)	NGC-1163	Screw, #6 x 3/8, PPHD, Drill Point, Zinc	101684 (qty 2 each)
See page A-30	Relay (K1 - Filament)	101273	Nut, #6-32, Keps Hex, Ext Tooth, Cres	102961 (qty 1)
See page A-30	Relay (K2 - Anode)	101273	Nut, #6-32, Keps Hex, Ext Tooth, Cres	102961 (qty 1)
See page A-30	Relay (K7 - All Cooling Fans)	101274	Nut, #6-32, Keps Hex, Ext Tooth, Cres	102961 (qty 1)
12	Thermostat, Magnetron (x2)	104228	Screw, #6 x 3/8, PPHD, Drill Point, Zinc	101684 (qty 2 each)
13	Transformer, Filament, 60 Hz (x2) Transformer, Filament, 50 Hz (x2)	NGC-3061-1 NGC-3061-2	Screw, #8 x 1/2, Serr Ph Truss Hd, Sheet Mtl	101688 (qty 4 each)
14	Transformer, HV, 60 Hz (x2) Transformer, HV, 50 Hz (x2)	NGC-3062-1 NGC-3062-2	Screw, #8 x 1/2, Serr Ph Truss Hd, Sheet Mtl	101688 (qty 4 each)
15	Waveguide Kit (x2)*	ENC-3008	Included	Included
16	Waveguide Cover (x2)	i1-9462	None	None
17	Waveguide Gasket (x2)*	i1-9331	Nut, #10-32, Serr Hex Flange, Zinc	100913 (qty 9 each)
18	Waveguide Seal (x2)*	i1-9486	None	None
Not Shown	Harness, Wiring, HV, MW Circuit 1 and 2	ENC-1402	None	None

* Items 16-18 are also included with item 15.



Oven Door and Related Parts

⚠ DANGER: Before removing any oven part, be sure the oven has completed “cooling down” (see “Step 9” on page 11) and is removed from the power source.

NOTE: For clarity, some components have been removed from the illustrations below.

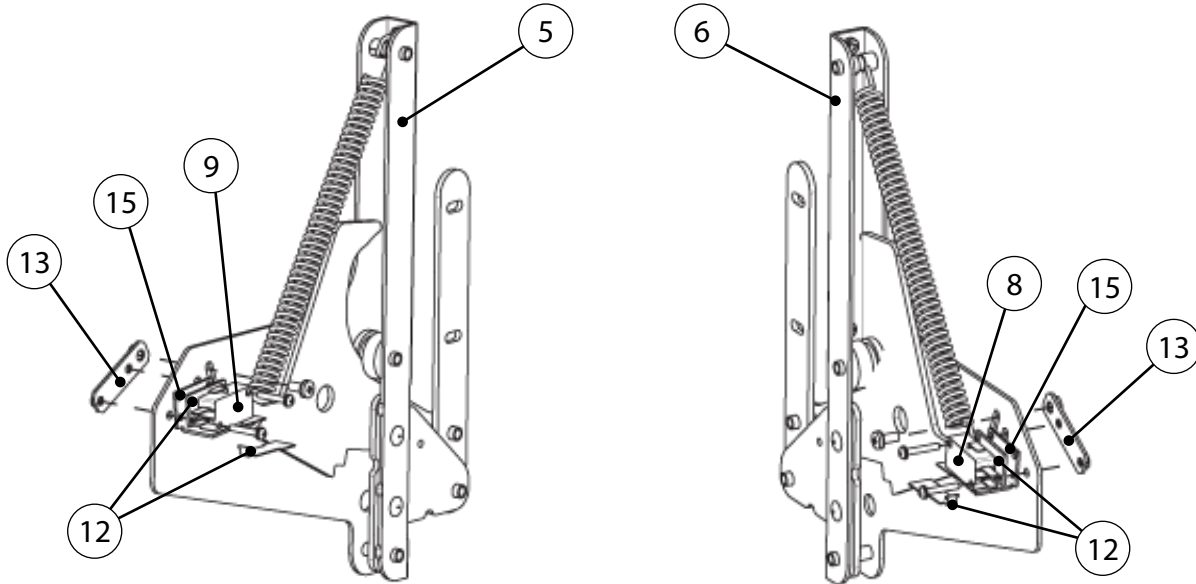

* When replacing the primary switch:

- a.) Discard one of the switches supplied with kit [NGC-3033](#)
- b.) Use the shorter screws (see Figure below)
- c.) Follow all instructions in the provided field service bulletins FSB-10057 and FSB-10094
- d.) Discard FSB-10055

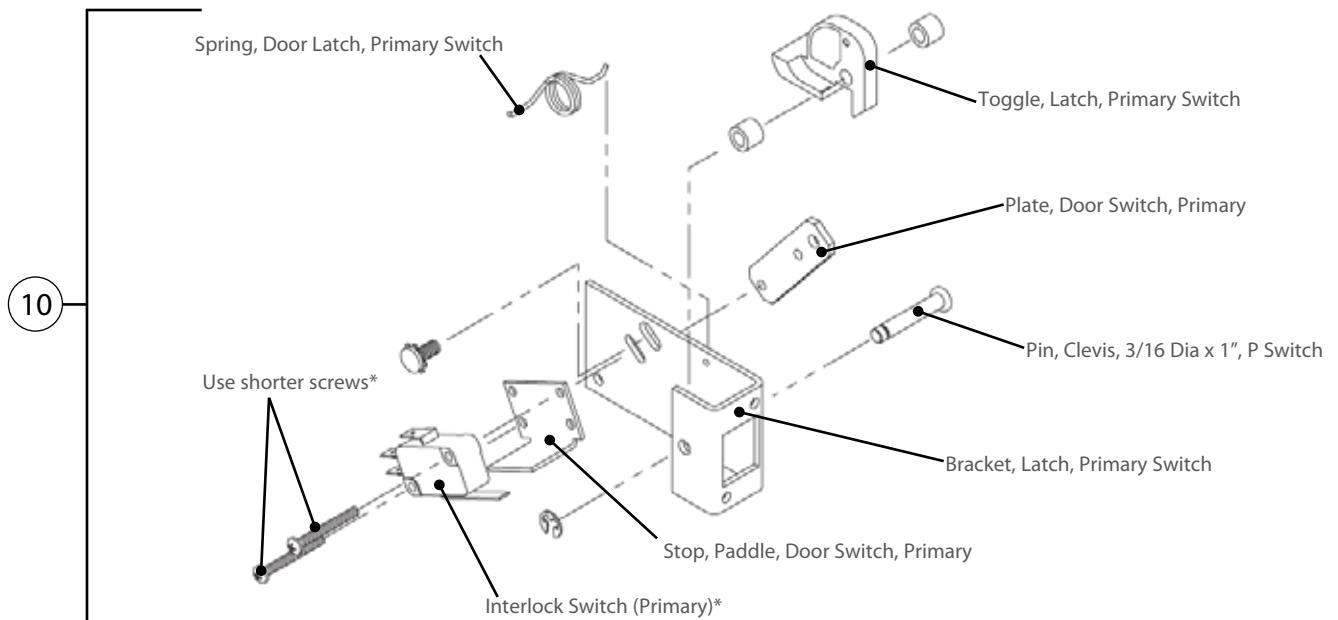
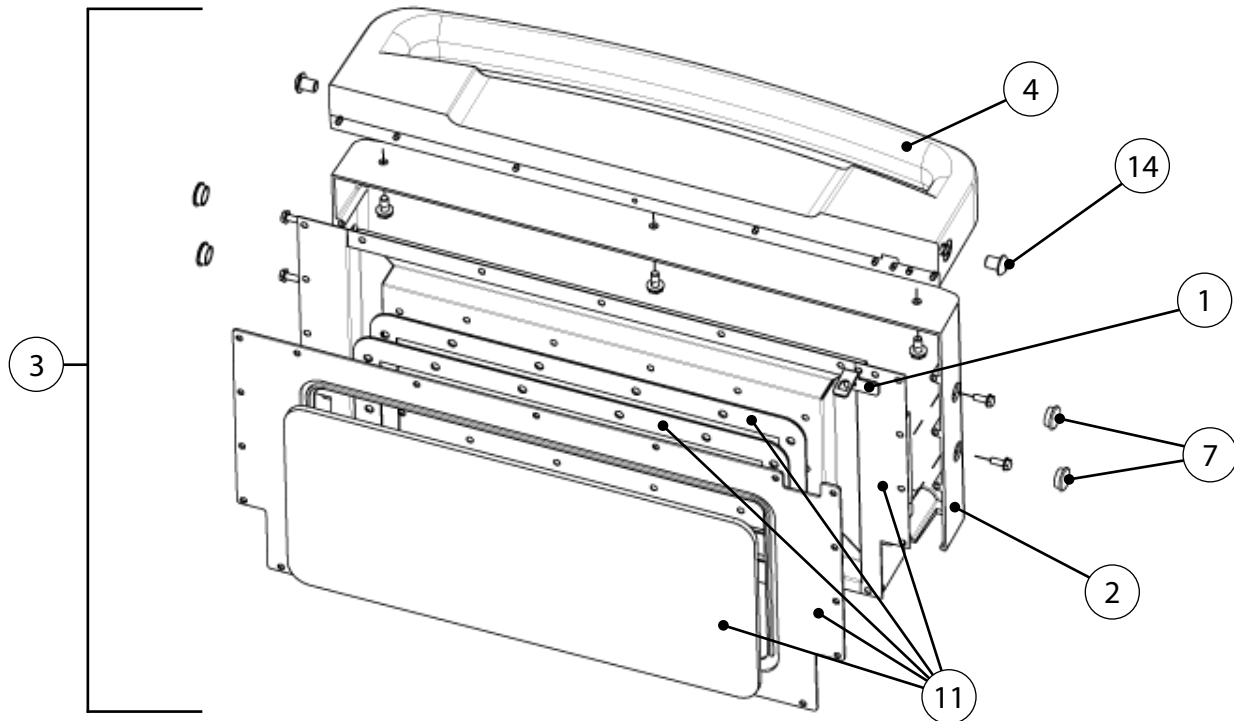

Figure Reference #	Item Description	Item Part Number	Fastener Description	Fastener Part Number
See page A-19	Badge, Logo, Encore/ Encore 2	ENC-1192	Nut, Push, 1/8	101293 (qty 2)
1	Catch, Latch	ENC-1131	Screw, #8 x 3/8, Security, Torx Hd	102748 (qty 2)
2	Cover, Door, Gray	ENC-1121-T001	Screw, #8 x 5/8, Ph Mod Truss Hd, Cres	101376 (qty 11)
3	Door, Entire Assembly	ENC-3003	Screw, #10-32 x 1/2, Hex, Serr, Zinc	101373 (qty 4)
4	Handle, Door, Black	ENC-1122-9005	Screw, #8 x 5/8, Ph Mod Truss Hd, Cres	101376 (qty 7)
5	Hinge, Left	i1-3220-1	Screw, #8-32 x 5/8, PFH, 100 Deg, SS	102811 (qty 3)
6	Hinge, Right	i1-3220-2	Screw, #8-32 x 5/8, PFH, 100 Deg, SS	102811 (qty 3)
7	Hole Plug, Black, 5/8" Dia (x4)	101195	None	None
8	Interlock Switch (Monitor)	102013	Screw, #4-40 x 3/4, Sems, PPHD, SS	102904 (qty 2)
9	Interlock Switch (Secondary)	102013	Screw, #4-40 x 3/4, Sems, PPHD, SS	102904 (qty 2)
10	Kit, Door Switch, Primary*	NGC-3033*	Included with Kit	Included with Kit
11	Kit, Shunt Plate	ENC-3007	Included with Kit	Included with Kit
12	Kit, Switch Offset, Shim and Replacement Tab (x2)	i1-3207	Screw, #4-40 x 3/4, Sems, PPHD, SS	102904 (qty 2)
13	Plate, Door Switch, S/M (x2)	NGC-1126	Screw, #4-40 x 3/4, Sems, PPHD, SS Screw, #8-32 x 3/8, PPHD, Int Sems, SS	102904 (qty 2 each) 102921 (qty 1 each)
See page A-30	Relay (K3 - Monitor)	101273	Nut, #6-32, Keps Hex, Ext Tooth, Cres	102961 (qty 2)
14	Screw, Door, Buttonhead (x2)	ENC-1220	None	None
15	Stop, Paddle, Door Switch, S/M (x2)	NGC-1324	Screw, #4-40 x 3/4, Sems, PPHD, SS	102904 (qty 2 each)



Control System



DANGER: Before removing any oven part, be sure the oven has completed “cooling down” (see “Step 9” on page 11) and is removed from the power source.

NOTE: For clarity, some components have been removed from the illustrations below.

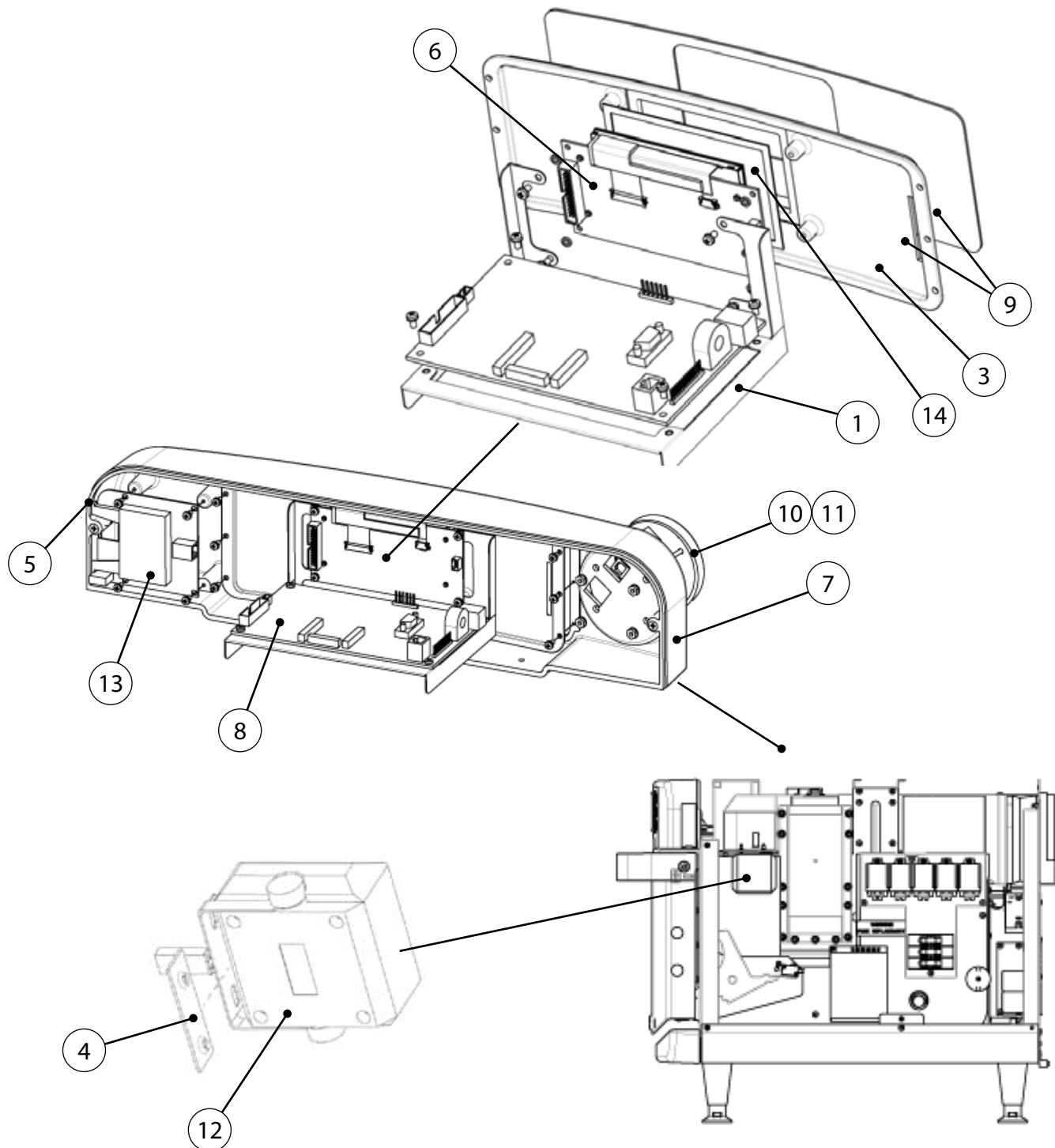
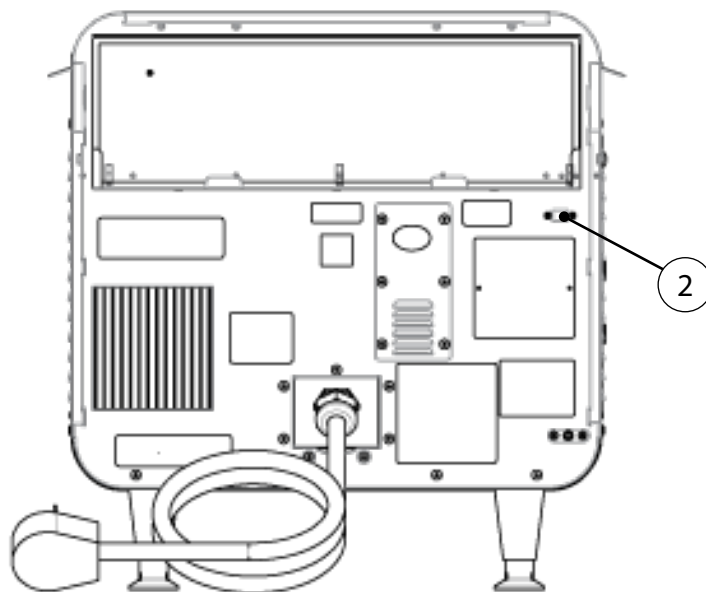



Figure Reference #	Item Description	Item Part Number	Fastener Description	Fastener Part Number
1	Bracket, Control Board, Support	ENC-1098	Screw, #6-32 x 1/4", Int Tooth, PPH, SS	102910 (qty 4)
Not Shown	Cable, Display, 5"	ENC-1311	None	None
2	Cable, Extension, Ethernet	100164	Screw, #4-40 x .25, PPH Sems Int Tooth, SS	101520 (qty 2)
Not Shown	Cable, Control Board to Light Ring	ENC-1312	None	None
Not Shown	Cable, Light Ring to USB/Card Reader	100182	None	None
3	Casting, Keypad	ENC-1116	Screw, #6-32 x 1/4", Int Tooth, PPH, SS	102910 (qty 6)
4	Clip, Speaker Mounting	HCT-4104	Screw, #8 x 1/2, Serr Ph Truss Hd, Sheet Mtl	101688 (qty 2)
5	Cover, USB Port	ENC-1189	None	None
6	Display	ENC-3011	Screw, #6-32 x 1/4", Int Tooth, PPH, SS Washer, #6-32, Neoprene	102910 (qty 4) 102439 (qty 4)
7	Housing, Display and Controls	ENC-1101	Screw, #8-32 x 3/8", PFH, 100 Deg, SS Screw, #8-32 x 5/8", PFH, 100 Deg, SS	102809 (qty 3) 102811 (qty 2)
8	Kit, Control Board	CON-3006*	Screw, #6-32 x 1/4", Int Tooth, PPH, SS	102910 (qty 4)
9	Kit, Keypad	ENC-3004**	Screw, #6-32 x 1/4", Int Tooth, PPH, SS	102910 (qty 6)
10	Kit, Light Ring (TurboChef)	ENC-3005-1	Nut, #6-32, Keps Hex, Ext Tooth, Cres	102961 (qty 4)
11	Kit, Light Ring (SUBWAY®)	ENC-3005-2	Nut, #6-32, Keps Hex, Ext Tooth, Cres	102961 (qty 4)
12	Kit, Speaker	CON-3003	Screw, #8 x 1/2, Serr Ph Truss Hd, Sheet Mtl	101688 (qty 2)
13	USB/Smart Card Reader	CON-7005	Screw, #6-32 x 1/4", Int Tooth, PPH, SS	102910 (qty 4)
14	Window, Display	ENC-1191	None	None
Not Shown	Wire, Display Jumper, 3-Pin	i1-9475	None	None
Not Shown	Harness, Wiring, Low Voltage	ENC-1403	None	None

* See Service Parts Price List for details.

** ENC-3004 (item 9) includes item 3.



Power Components

 **DANGER:** Before removing any oven part, be sure the oven has completed “cooling down” (see “Step 9” on page 11) and is removed from the power source.

NOTE: For clarity, some components have been removed from the illustrations below.

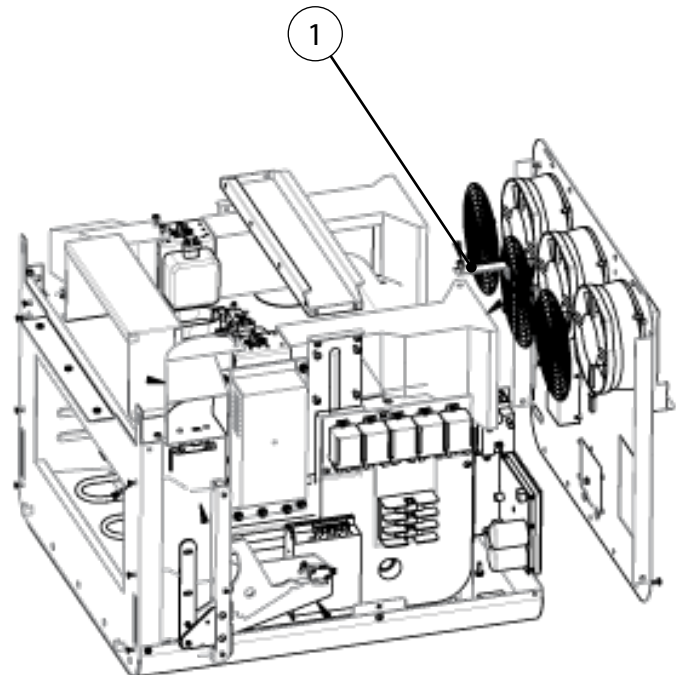
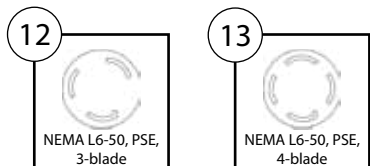
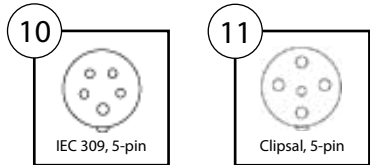
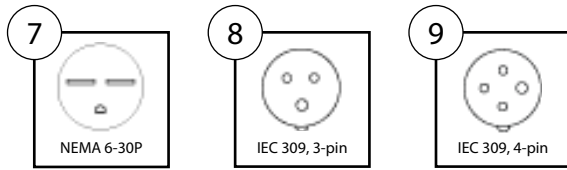
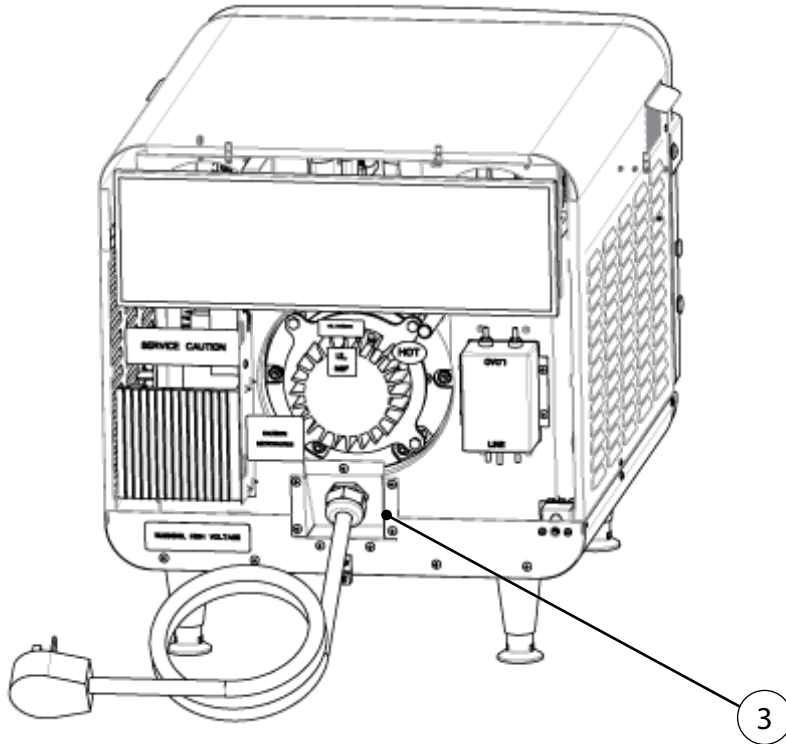
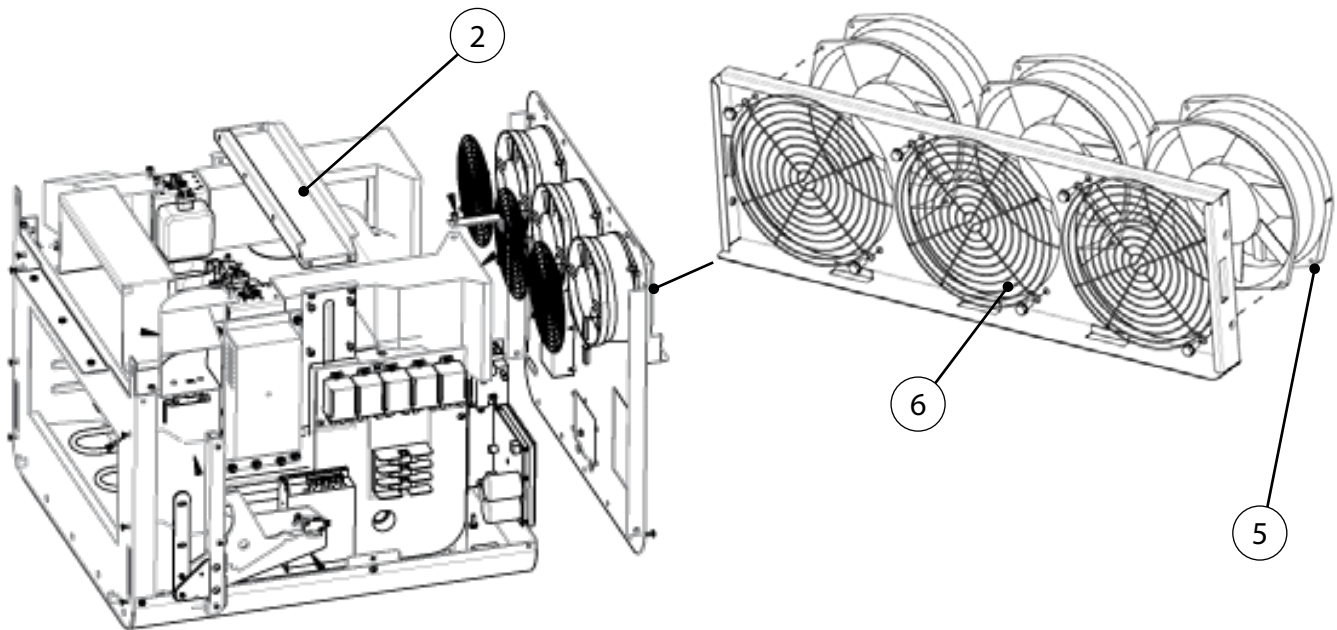



Figure Reference #	Item Description	Item Part Number	Fastener Description	Fastener Part Number
1	Bracket, Back Wall Support (Bracket Only)	ENC-1374	Screw, #8 x 1/2, Serr Ph Truss Hd, Sheet Mtl	101688 (qty 2)
2	Bracket, Cooling Duct	ENC-1206	Screw, #8 x 1/2, Serr Ph Truss Hd, Sheet Mtl	101688 (qty 4)
3	Bracket, Power Cord	ENC-1388	Screw, #8 x 1/2, Serr Ph Truss Hd, Sheet Mtl	101688 (qty 7)
4	EMI Filter, 1 Ph	100543	Screw, #8 x 1/2, Serr Ph Truss Hd, Sheet Mtl	101688 (qty 4)
5	Fan, Cooling, Electrical Compartment	TC3-0433	Screw, #10-32 x 1/2, Hex Wshr Hd, Type 23	101408 (qty 2 each)
6	Finger Guard	100086	Screw, #10-32 x 1/2, Hex Wshr Hd, Type 23	101408 (qty 2 each)
7	Power Cord, 60 Hz, 208-240 VAC, 1 Ph	100187	Nut, #10-32, Keps, Ext Tooth, SS	102963 (qty 3)
8	Power Cord, 50 Hz, 220-230 VAC, 1 Ph	100195	Nut, #10-32, Keps, Ext Tooth, SS	102963 (qty 3)
9	Power Cord, 50/60 Hz, 220-230 VAC, 3 Ph	100194	Nut, #10-32, Keps, Ext Tooth, SS	102963 (qty 4)
10	Power Cord, 50/60 Hz, 380-415 VAC, 3 Ph	103187	Nut, #10-32, Keps, Ext Tooth, SS	102963 (qty 5)
11	Power Cord, Aus/NZ, Clipsal, 400V, 3Ph	103195	Nut, #10-32, Keps, Ext Tooth, SS	102963 (qty 5)
12	Power Cord, Japan, 1 Ph	NGC-1390	Nut, #10-32, Keps, Ext Tooth, SS	102963 (qty 3)
13	Power Cord, Japan, 3 Ph	NGC-1383	Nut, #10-32, Keps, Ext Tooth, SS	102963 (qty 4)

See Page A-30 and A-31 for more power components.



Power Components, Continued

 **DANGER:** Before removing any oven part, be sure the oven has completed “cooling down” (see “Step 9” on page 11) and is removed from the power source.

NOTE: For clarity, some components have been removed from the illustrations below.

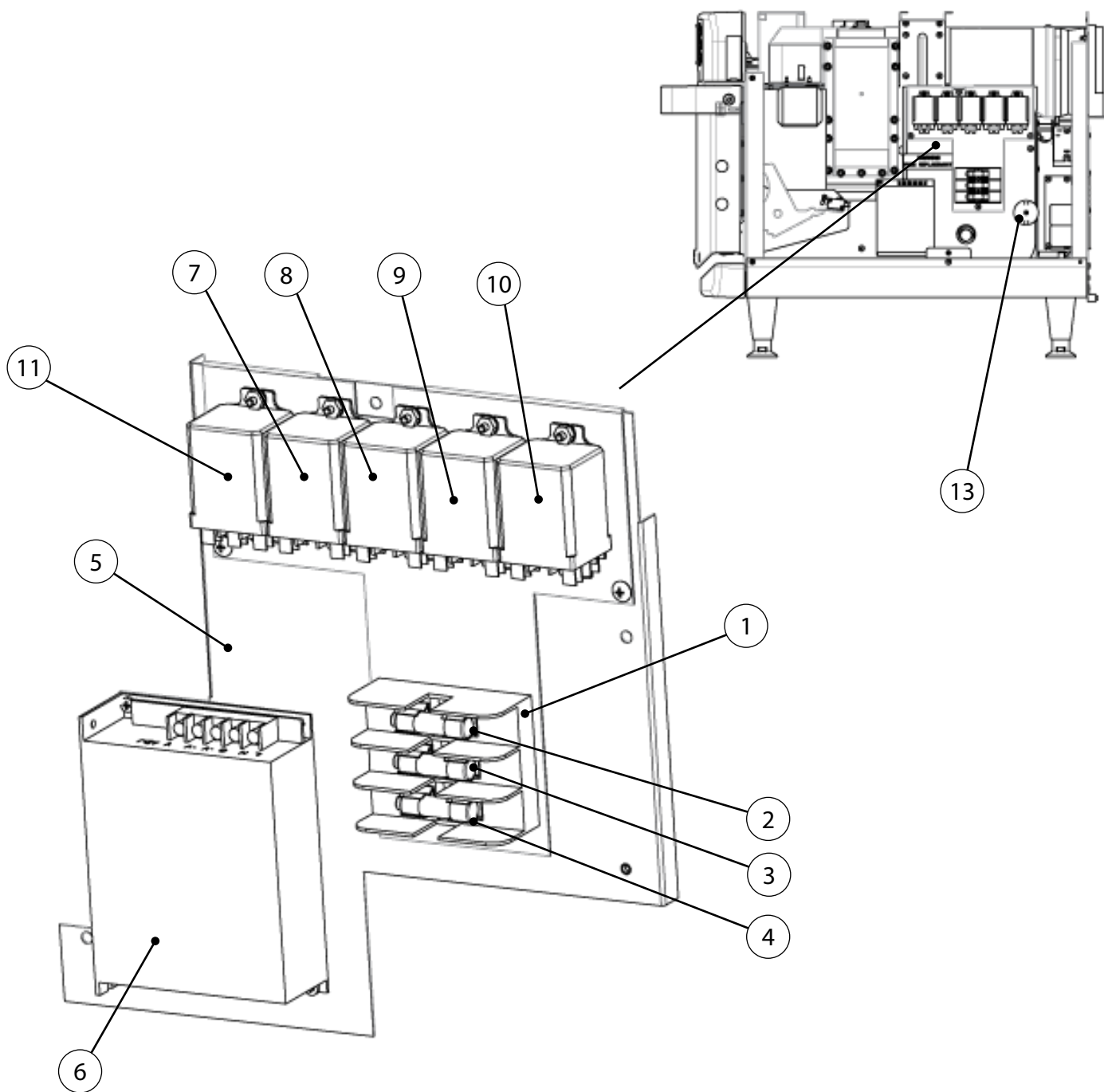
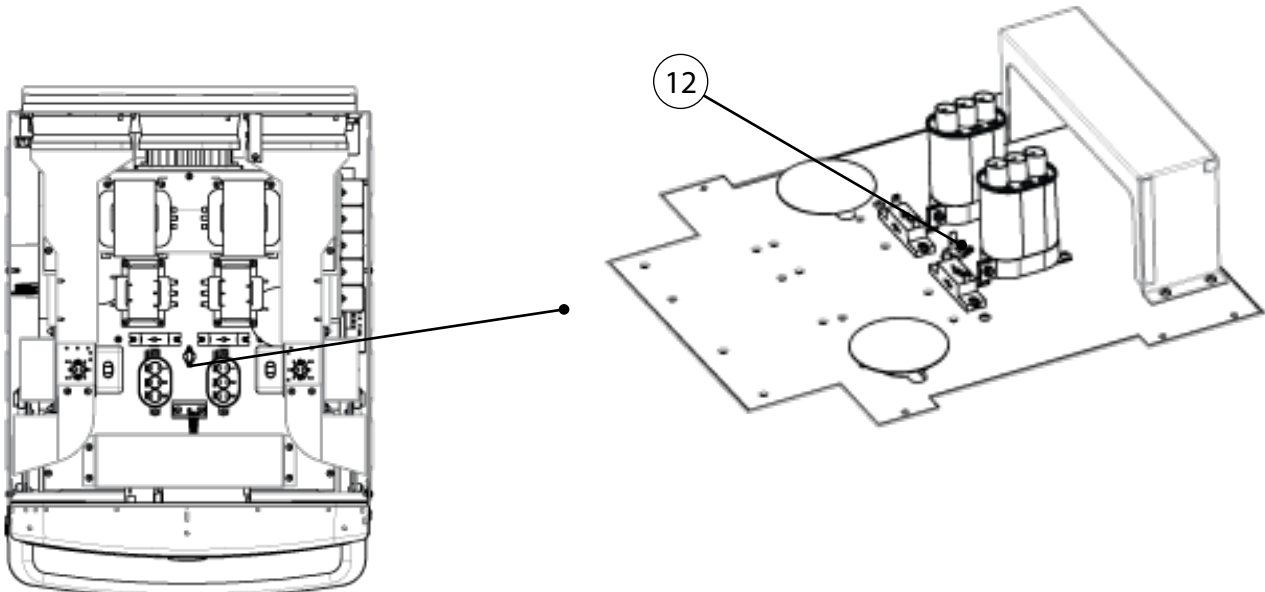

Figure Reference #	Item Description	Item Part Number	Fastener Description	Fastener Part Number
1	Fuse Block, 3 Pole, 30 Amp	103566	Screw, #8 x 1/2, Serr Ph Truss Hd, Sheet Mtl	101688 (qty 2)
2	Fuse, F1, 12 amp, Class CC, ATMR	100592	None	None
3	Fuse, F2, 12 amp, Class CC, ATMR	100592	None	None
4	Fuse, F3, 20 amp, Class CC, ATMR	100599	None	None
5	Panel, Electrical, RHS (Panel Only)	ENC-1336	Screw, #8 x 1/2, Serr Ph Truss Hd, Sheet Mtl	101688 (qty 3)
6	Power Supply, 24 VDC	101211	Screw, #6 x 3/8, PPHD, Drill Point, Zinc	101684 (qty 2)
7	Relay (K1 - Filament)	101273	Nut, #6-32, Keps Hex, Ext Tooth, Cres	102961 (qty 1)
8	Relay (K2 - Anode)	101273	Nut, #6-32, Keps Hex, Ext Tooth, Cres	102961 (qty 1)
9	Relay (K3 - Monitor)	101273	Nut, #6-32, Keps Hex, Ext Tooth, Cres	102961 (qty 1)
10	Relay (K6 - Voltage)	101272	Nut, #6-32, Keps Hex, Ext Tooth, Cres	102961 (qty 1)
11	Relay (K7 - Magnetron Cooling Fan)	101273	Nut, #6-32, Keps Hex, Ext Tooth, Cres	102961 (qty 1)
12	Thermostat, Cooling Fan, EC, 120F	102086	Screw, #6 x 3/8, PPHD, Drill Point, Zinc	101684 (qty 2)
13	Voltage Sensor (North America only)	100783	Screw, #6-32 x 1, PPH, SS	101580 (qty 1)
Not Shown	Harness, Wiring, Heater	ENC-1401	None	None
Not Shown	Harness, Wiring, Cooling Fan	ENC-1405	None	None
Not Shown	Harness, Wiring, Line Voltage	ENC-1404	None	None



For service or information:

WITHIN NORTH AMERICA CALL

Customer Support *at* 800.90TURBO

OUTSIDE NORTH AMERICA CALL

+1 214.379.6000 or Your Authorized Distributor



Part Number: ENC-1143 / Revision F / January 2014
Country Code: NA/EU

Global Operations

2801 Trade Center Drive
Carrollton, Texas 75007 USA
+1 214.379.6000 PHONE
+1 214.379.6073 FAX

Customer Support:

800.90TURBO
+1 214.379.6000
turbochef.com